

# The Guide

Pocket book reference for truss installation



## Note

*"The Guide" is intended to be used only for roof trusses supplied by accredited Multinail Truss Fabricators.*

*"The Guide" is intended as a guide only to the installation of Timber Roof Trusses and should only be used by properly trained and qualified staff who are competent in the installation of roof trusses.*

*If you have any doubts about using or interpreting "The Guide" please do not hesitate to contact your Truss Fabricator or Multinail Australia for advice and assistance.*

*As truss installation invariably involves working at heights, you should undertake a risk assessment for all construction sites as well as following all relevant workplace safety practices and legislative requirements.*

# Table of contents

<b>1. Check first!</b> .....	<b>1</b>
<b>2. Check this guide is applicable to your job</b> .....	<b>2</b>
<b>3. Durability notice.</b> .....	<b>3</b>
3.1 Sarking. ....	3
<b>4. Transport and storage</b> .....	<b>4</b>
4.1 Protection from water. ....	4
<b>5. Safety on site using timber engineered components.</b> .....	<b>5</b>
<b>6. Lifting</b> .....	<b>7</b>
<b>7. Recommendations for temporary bracing</b> .....	<b>8</b>
7.1 Hip or dutch hip end roof .....	9
7.2 Gable-end roof .....	10
<b>8. Installation tolerances</b> .....	<b>11</b>
8.1 Bow .....	11
8.2 Plumb. ....	12
8.3 Spacing .....	12
8.4 Camber .....	12
<b>9. Truss laminations</b> .....	<b>13</b>
9.1 Double Trusses. ....	13
9.2 Triple Trusses .....	13
<b>10. Truss connection</b> .....	<b>14</b>
10.1 Hip end fixing details. ....	14
10.1.1 Hip-end connection for low wind area (wind classification N1, N2, N3 or C1) ..	15
10.2 Hip-end connection for high wind area (wind classification N4, C2 or C3). ....	19
10.3 Valley (saddle) trusses. ....	23
10.3.1 Valley truss connection for low wind (design wind speed N1, N2, N3 or C1). ..	23
10.3.2 Valley truss connection for high wind (design wind speed N4, C2 or C3) .....	25
10.4 Gable Truss with Outrigger Positioning .....	27
10.5 Nail-Gun edge distances .....	29
10.6 Truss boot installation. ....	31

<b>11. Waling plate fixing details to dutch hip girders</b>	<b>32</b>
<b>12. Roof battens</b>	<b>40</b>
12.1 Roof batten splicing	41
<b>13. Top chord bracing</b>	<b>43</b>
13.1 Steelbrace for gable roof	43
13.2 Spans up to 8m	45
13.3 Spans of 8m to 13m	48
13.4 Spans of 13m to 16m	52
13.5 Steelbrace for hip roof	53
13.5.1 Bracing requirement for standard trusses	53
13.6 Bracing requirement for jack trusses	54
13.7 Steelbrace for dual-pitched roof	56
13.8 Steelbrace for bell roof	57
13.9 Steelbrace for mono-pitched roof	57
13.10 Fixing of steelbrace	58
<b>14. Bottom chord bracing</b>	<b>62</b>
14.1 Ceiling battens	62
14.2 Bottom chord ties	62
<b>15. Web bracing</b>	<b>64</b>
<b>16. Walls</b>	<b>65</b>
16.1 Non-loadbearing walls	65
16.1.1 Fixing to top plates of non-loadbearing walls	66
16.1.2 Internal wall brackets	67
16.2 Loadbearing walls	67
16.3 Bearing plates	68
16.4 Steel Nogs	69
<b>17. Parallel Chord Trusses</b>	<b>71</b>
17.1 Correct orientation	71
17.2 Bracing	72
17.3 Strongbacks	73
<b>18. Appendix - Document control</b>	<b>75</b>

## 1. Check first!

This guide is based on Australian Standard AS4440 - Installation of nailplated timber roof trusses.

Before commencing, you must check that your building falls within the limits shown in Section 2.

Before you erect trusses you must check to ensure that they comply with the specific requirements of the job.

Special consideration is required for the support of additional loads (e.g. hot water tanks, solar heaters, air conditioners, etc) or the construction of buildings to withstand high wind loads.

You must ensure that all the relevant information has been passed to the truss fabricator and that you use trusses only in the application for which they are intended.

Before you erect trusses, you must inform the roof truss supplier of any scaffolding, edge protection devices, anchor points, etc. with the potential to add loads to the structure at any stage of construction.

The supporting structure must be adequate to support and hold down the trusses and their associated roof, ceiling or floor loads.

**You must fully understand the information contained in this brochure plus any supplementary information before attempting to erect trusses.**



### SAFETY NOTE

A timber truss is an engineered structural component, designed and manufactured for specific conditions. You must not remove timber (e.g. by sawing) from any part of the truss as this may seriously impair its strength and lead to failure of the structure.

## 2. Check this guide is applicable to your job

- I. Residential structures (BCA Classes 1, 2, 3 and 10) and light commercial structures.
- II. Maximum Roof Pitch of 45°.
- III. Maximum Span 16m.
- IV. Shape in plan view to be rectangular or near-rectangular, or a series or a combination of rectangular shapes or near-rectangular shapes, including splayed-end and boomerang-shaped buildings and the like, and projections such as bay windows.
- V. Maximum truss spacing of:
  - A. 900mm; or
  - B. 1200mm, for sheet metal roofs in an area of design wind speed up to N3.
- VI. Maximum design gust wind speed of 74m/s wind classification C3 for ultimate limit state method in accordance with AS/NZS 1170.2 or AS4055.

Figure A1-03-01-03

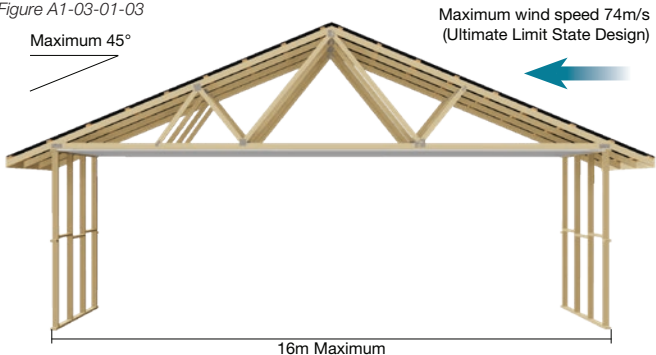

APPLIES:  (Tick)

### **3. Durability notice**

No galvanised nailplates should be permanently exposed to weather or other sources of moisture.

For environments where the atmosphere may be conducive to corrosion (e.g. some types of industrial and agricultural buildings, swimming pools or buildings near the ocean and subject to salt spray) consideration should be given to the use of stainless steel nailplates and fixings.

#### **3.1 Sarking**

Multinail recommends that all roofs be sarked to prevent moisture entering the roof space through gaps in tiles or via condensation on metal sheeting. It is mandatory that all roofs be sarked as per recommendations in the Building Code of Australia and AS2050 "Installation of roof tiles" which includes but is not limited to all roofs in a wind speed area greater than N3. Refer to tile manufacturers recommendations for further information.

## 4. Transport and storage

Trusses may be transported either vertically or horizontally. Regardless of the transport orientation, all trusses must always be fully supported.

No excess from the tie-down straps or bracing should be on any part of the truss.

Trusses should be inspected on arrival at site. Any damaged trusses should be reported immediately.

Do not site repair any truss without the approval of the truss fabricator.

Bundles (or individual trusses) should be stored flat and kept dry. Gluts or packers should be placed at 3000mm maximum spacing to support the trusses off the ground.

### 4.1 Protection from water

To ensure the long-term structural integrity of trusses, the trusses must be protected from exposure to water. This applies to the timber from the time prior to truss fabrication to after the time the roofing material has been installed. Failure to protect the timber from water exposure may lead to failure of trusses.





## 5. Safety on site using timber engineered components

Floor Trusses, Wall Frames and Roof Trusses, etc. are designed to be part of a structural system that includes the battens, bracing, trusses, binders, ceiling, supporting structure and the connection of these elements. Each element on its own may not be strong but fixed together they form a strong, stiff and stable system.

Until all these elements are fully assembled, fixed and braced, the roof structure and building will not have achieved its final strength.

To prevent possible injury to construction personnel and/or damage to the engineered components, anyone working with the engineered structural components must exercise common sense and a large degree of caution during the construction phases.

Appropriate protection of people and products should be considered at all times.

Some common sense protection items include:

- Ensure that all elements are connected to each other as designed.
- Ensure that all elements are all equally braced for dead load, live load and wind load.
- Use appropriate lifting devices that do not damage existing components already installed.
- Use appropriate temporary bracing, scaffolding and planks prior to working on the engineered components.
- Do not load any truss, including standing on, until all temporary bracing for that truss has been installed and stabilised and all girder boot fixings have been correctly fastened.
- Do not apply any load, including standing or leaning on, to the overhang of any truss especially jack and creeper trusses/rafters until the fascia is installed.
- Do not stack excessively heavy loads of materials on truss components.
- Ensure adequate bracing is firmly attached to enable the unfinished structure to support construction live loads, material and any wind loads that may occur overnight and during the day.
- Other as applicable to each job.

Since every job is different in the conditions that prevail on site, it is the builder's responsibility to ensure that these conditions are closely considered and met before, during and after construction while work is still occurring on the site - also while other trades are involved.

Note that any recommendation in this document regarding the above issues are a suggestion only and may not be applicable to every job. Additional safety measures to the above may be required to protect the workers, components and the environment.



## 6. Lifting

The following diagrams show the correct method of lifting and handling trusses on site. Trusses may also be pulled up to the wall top plates using skids placed approximately 3m apart.

### Spans under 9m

Figure C1-02-01-01

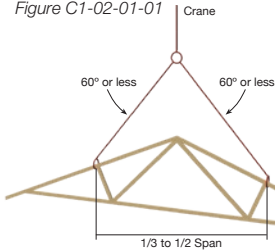
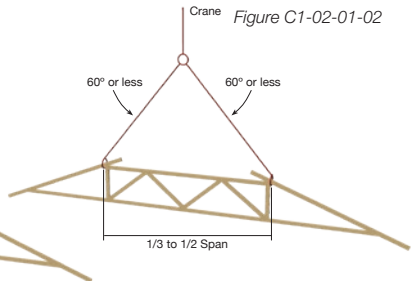

Figure C1-02-01-02



### Spans 9m to 16m

Figure C1-02-01-03

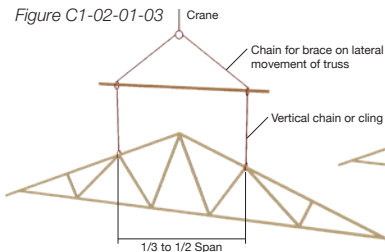
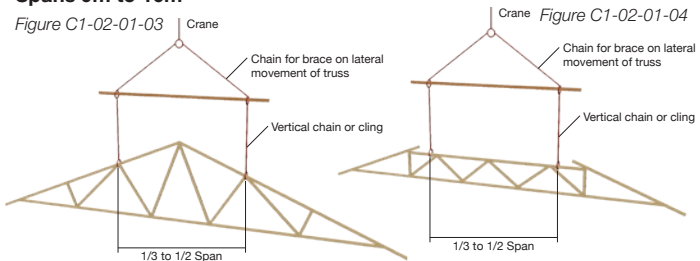

Figure C1-02-01-04



Slings should be located at equal distances from the truss centreline, and be approximately one-third to one-half truss length apart.



### SAFETY NOTE

When lifting, special care must be taken to avoid damage to truss joints. If it is necessary to handle a truss on its side, precautions must be taken to avoid damage due to sagging. Trusses must never be lifted by the apex joint only. Spreader bars (with attachment to panel points) must be used where the span exceeds 9m. For spans over 16m contact the Multinail Engineering Department.

## 7. Recommendations for temporary bracing

This provides temporary bracing details recommended for gable, hip and dutch-hip end roof trusses.

The first truss should be erected correctly, straight and vertical, and temporarily braced in position.

Each successive truss should then be spaced correctly and fixed back to the first truss with temporary ties to top chord at a maximum spacing of 3000mm and to bottom chord at a maximum spacing of 4000mm.

Use temporary ties as per the following table:

Minimum size of temporary ties		
Truss spacings	For top chords	For bottom chord
Up to 900mm	25 x 50 F5	35 x 70 F5
Over 900mm up to 1200mm	35 x 70 F5	35 x 70 F5

Ties should be fixed to each truss with a minimum of one 75mm x 3.05Ø nail.

### Important Notes



1. Temporary ties are not designed to be a trafficable platform.
2. Steelbrace is not acceptable for temporary bracing.

## 7.1 Hip or dutch hip end roof

Temporary bracing for a hip or dutch-hip is achieved by erecting and fixing the truncated girder, or dutch-hip girder truss, in the correct position to the top plates and bracing the girder truss back to the corner of the building as shown in Figure below.

Ensure no weight or load is placed on the truss overhangs, especially in the vicinity of the hip overhang, until all necessary structural members, such as structural fascias and roof battens, have been fully installed.

### Temporary bracing for hip or dutch-hip end roof

Figure C2-06-01-02

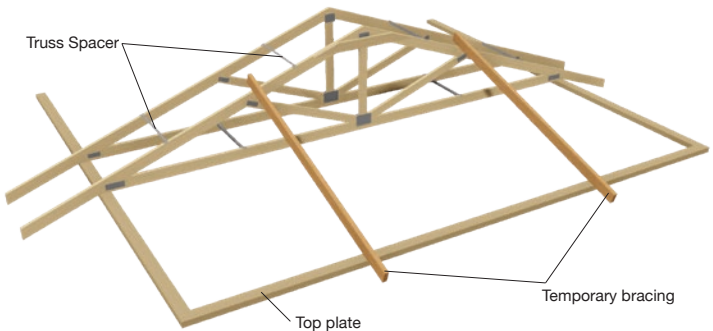

**CHECK BRACED PROPERLY:**

(Tick)

## 7.2 Gable-end roof

Temporary bracing for a gable-end roof is achieved by erecting and fixing the first truss to top plates at one end of the roof and bracing the truss to a rigid element; eg, the ground, as shown in Figure below.

Figure C4-02-05-01

Temporary longitudinal ties to truss top chords at 3000mm centres

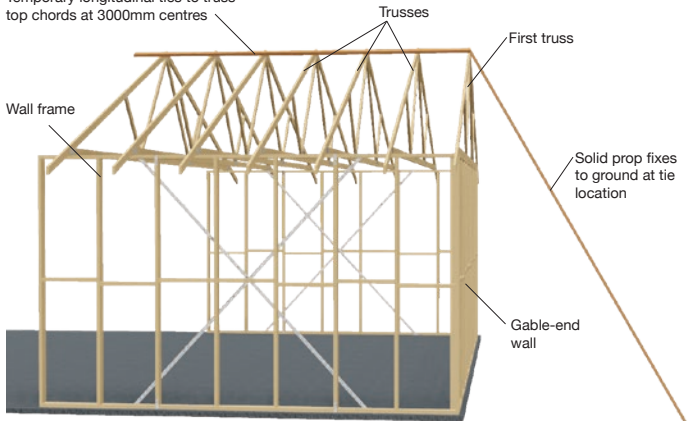

**CHECK BRACING:**  (Tick)

## 8. Installation tolerances

For proper truss safety and performance, trusses must be installed straight and vertical and in their correct position as specified in sections 8.1 to 8.2.

NOTE: The best method for ensuring correct truss positioning is to mark the locations on the top plate or other supporting elements in accordance with the truss layout prior to truss installation.

### 8.1 Bow

Trusses must be erected with minimal bow in the truss and in any chord, with a tolerance not exceeding the lesser of length of the bowed section/200 and 50mm, where length is defined in Figure C1-01-01-04 or Figure C1-01-01-05.

Figure C1-01-01-04

Top view

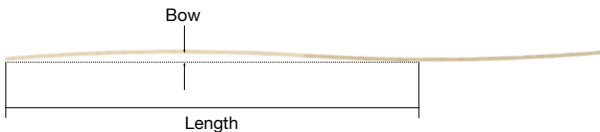

Side view



C1-01-01-04

Figure C1-01-01-05

Top view

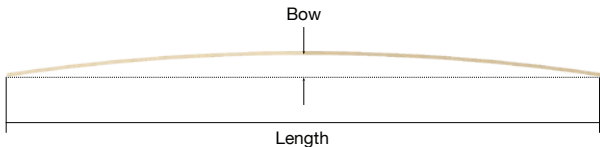

Side view



C1-01-01-05

CHECK BOW:  (Tick)

## 8.2 Plumb

Trusses must be erected so that no part of the truss is out of plumb with a tolerance not exceeding the lesser of height/50 and 50mm where the height is measured at the location under consideration (see Figure C1-01-01-03).

**CHECK PLUMB:**  (Tick)

## 8.3 Spacing

Trusses must be erected at a spacing not exceeding that specified in the design specifications or truss layout.

**CHECK SPACING:**  (Tick)

## 8.4 Camber

Trusses are built with a camber in the bottom chord which is intended to compensate for the long-term deflection due to dead loads. A girder truss will have more camber than other trusses.

Figure A1-02-02-10

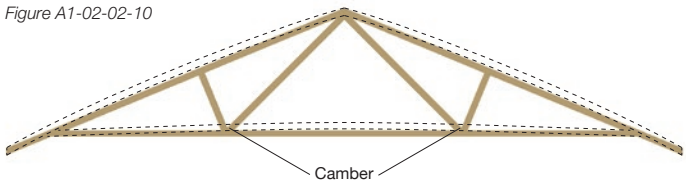

**CHECK CAMBER:**  (Tick)

Figure C1-01-01-03

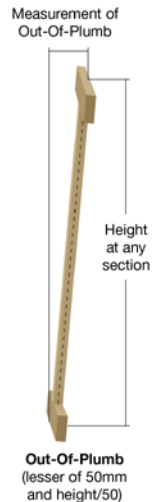



## 9. Truss laminations

### 9.1 Double Trusses

It is necessary that double trusses are nailed together prior to loading the roof.

**In Chords:** two (2) rows (staggered) of 3.05mm diameter nails at maximum 450 centres from one side, or use 1/Green Tip screw.

**In Webs:** one (1) row of 3.05mm diameter nails at maximum 450 centres from one side. A minimum of two nails per web is required or use 1/Green Tip Screw at 600 centres.

**Nail Lengths:**

65mm long for up to 38mm thick laminates.

75mm long for up to 50mm thick laminates.

*Special truss design fixings may be specified in excess of this.*

### 9.2 Triple Trusses

It is necessary that triple trusses are nailed together prior to loading the roof

**In Chords:** Nail as for double truss from each side, and also use 1/M12 bolt at joints or 2/Green Tip Screws from each side at every web junction through the top chord, plus at the heel joint through the top chord.

If bolted brackets are used on the bottom chord at 1200mm centres or less, then these bolts are sufficient for bottom chord.

**In Webs:** one (1) row of 3.05mm diameter nails at maximum 450 centres from each side. A minimum of two nails per web is required or use 1/Green Tip Screw at 600 centres.

**Screw Lengths:**

65mm long Green Tip Screws for up to 38mm thick laminates.

100mm long Black Tip Screws for up to 50mm thick laminates.

*Special truss design fixings may be specified in excess of this.*

CHECK:  (Tick)

### Double Trusses



Figure C1-03-02-01

### Triple Trusses



Figure C1-03-03-01

## 10. Truss connection

This section specifies the minimum requirements for truss-to-truss connections. At least two 3.05Ø nails, with a penetration of 10 times the nail diameter into supporting member, shall apply to connect each member.

Note that different connection details apply at different design wind speeds.

**MY DESIGN WIND SPEED IS :**

### 10.1 Hip end fixing details

Ensure no weight or load is placed on the truss overhangs, especially in the vicinity of the hip overhang, until all necessary structural members, such as structural fascias, props and roof battens, have been fully installed.

### 10.1.1 Hip-end connection for low wind area (wind classification N1, N2, N3 or C1)

Connection of jack, creeper and hip trusses at a hip-end roof for design wind speed N1, N2, N3 or C1 shall be in accordance with the details shown. These details are suitable for a maximum truncated girder station of 3600mm.

The fixing requirements for hip ends in this section are based on the design criteria that are governed by dead loads.

Figure C2-01-01-01

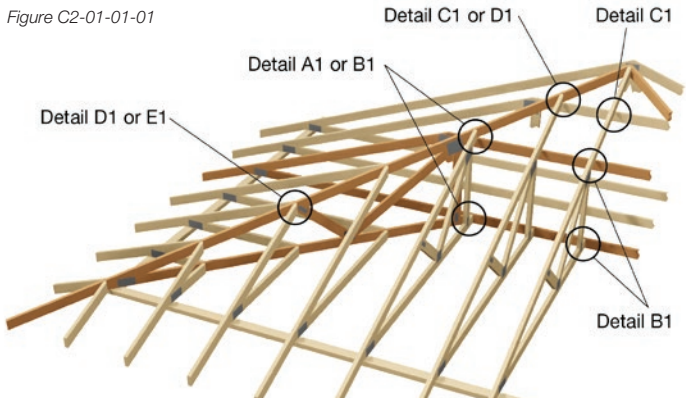

**Note 1:** For effective skew nailing, the nail shall be driven into one member not closer than 25mm to no more than 38mm from the area in contact with the adjacent member. The nail shall be driven at an angle between 30° and 45° to the face into which the nail is driven.

**Note 2:** Where nails are smaller than the nominated size or other than plain shank nails, or machine driven or both, their performance shall not be inferior to the nail sizes given.

**Note 3:** Roof battens or purlins and ceiling battens shall be fixed to trusses in accordance with the approved specification.

**Note 4:** Top Chord details of A1 and B1 also apply to GTG (Girder Truncated Girder)

## Fully Trussed Hip End Detail Low Wind (N1, N2, N3 or C1)

### Detail A1

#### Hip truss to truncated girder truss.

**Top Chord** - one framing anchor bent to suit, with 4/30mm x 2.8Ø reinforced-head nails into the side of each top chord for truncated girder.

**Bottom Chord** - 3/75mm x 3.05Ø nails.

Figure C2-01-01-02

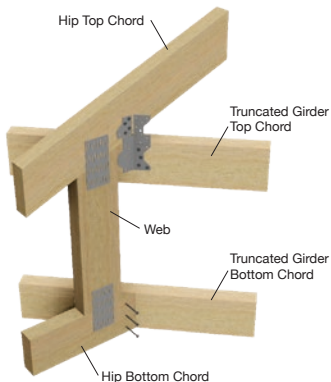

CHECK:  (Tick)

### Detail B1

#### Jack truss to truncated girder truss.

**Top Chord** - one framing anchor bent to suit, with 4/30mm x 2.8Ø reinforced-head nails into the side of each top chord for truncated girder.

**Note:** For design wind speed up to N2, tile roofs, truncated girder with spans up to 8000mm and station up to 2400mm, detail C1 may be used.

**Bottom Chord** - 3/75mm x 3.05Ø in end of jack truss.

Figure C2-01-01-06

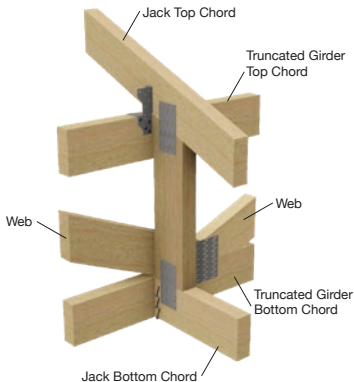

CHECK:  (Tick)

## Fully Trussed Hip End Detail Low Wind (N1, N2, N3 or C1)

### Detail C1

Figure C2-01-01-08

#### Extended jack truss to top chord to truncated standard trusses.

2/75mm x 3.05Ø skew nails into the side of each top chord.

**Note:** Follow Detail A1 and B1 when a TS become a GTG (Girder Truncated Girder).

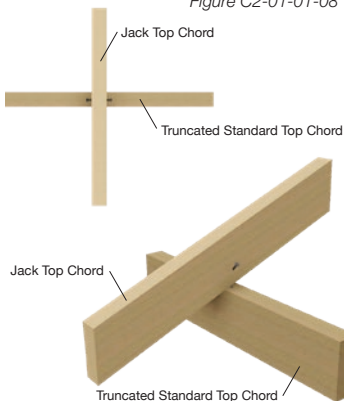

CHECK:  (Tick)

### Detail D1

Figure C2-01-01-09

#### Creeper or jack truss to hip truss (maximum creeper/jack station 1800mm)

**Top Chord** - 3/75mm x 3.05Ø nails through jack truss top chord into hip truss top chord.

**Bottom Chord** - 3/75mm x 3.05Ø nails through jack truss bottom chord to hip truss bottom chord.

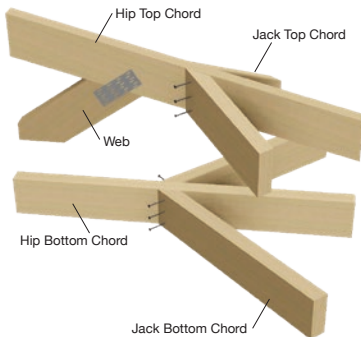

CHECK:  (Tick)

## Fully Trussed Hip End Detail Low Wind (N1, N2, N3 or C1)

### Detail E1

Figure C2-01-01-10

**Creeper or jack truss to hip truss (maximum creeper/ jack station 3000mm)**

**Top Chord** - fix as detail D1 plus one Mitre plate with 6/30mm x 2.8Ø reinforced-head nails to each top chord.

**Bottom Chord** - 3/75mm x 3.05Ø nails through jack truss bottom chord to hip truss bottom chord.

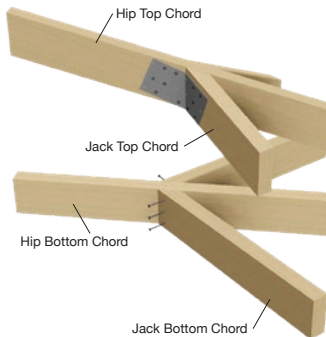

CHECK:  (Tick)

## 10.2 Hip-end connection for high wind area (wind classification N4, C2 or C3)

Connection of jack and hip trusses at a hip-end roof for design wind classification N4, C2 or C3 shall be in accordance with the details shown. These details are suitable for a maximum truncated girder station of 3600mm.

Figure C2-02-01-01

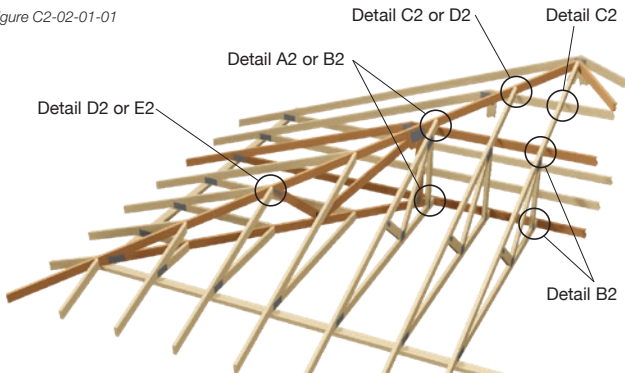

- Note 1:** For effective skew nailing, the nail shall be driven into one member not closer than 25mm to no more than 38mm from the area in contact with the adjacent member. The nail shall be driven at an angle between 30° and 45° to the face into which the nail is driven.
- Note 2:** Where nails are smaller than the nominated size or other than plain shank nails, or machine driven, or both, their performance shall not be inferior to the nail sizes given.
- Note 3:** Roof battens or purlins and ceiling battens shall be fixed to trusses in accordance with the approved specifications.
- Note 4:** Where framing anchors or G.I. straps are specified, they shall be fixed in accordance with the approved specifications.
- Note 5:** Jack trusses are assumed to be supported on the horizontal top chord of the truncated girder.

## Hip-end connection for high wind area (wind classification N4, C2 or C3)

### Detail A2

Figure C2-02-01-02

#### Hip truss to truncated truss.

**Top Chord** - 1/30mm x 0.8mm G.I. looped strap, with 4/30mm x 2.8Ø reinforced-head nails to each leg.

**Bottom Chord** - use one mitre plate with 6/2.8Ø nails into each face.

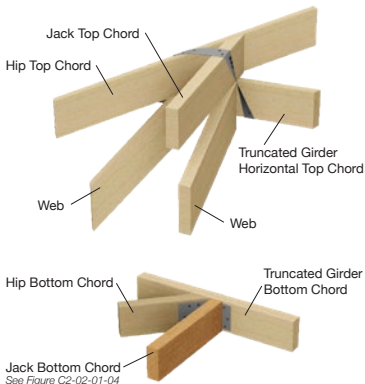

CHECK:  (Tick)

### Detail B2

Figure C2-02-01-03

#### Method 1

#### Jack truss to truncated girder truss.

**Top Chord** - Station up to 2400mm - one framing anchor with 4/30mm x 2.8Ø reinforced-head nails into the side of each top chord.

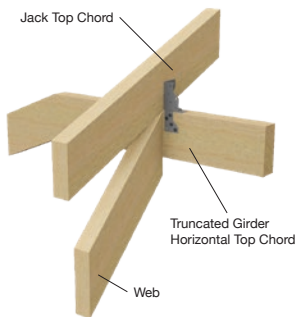

CHECK:  (Tick)



## Hip-end connection for high wind area (wind classification N4, C2 or C3)

### Method 2

#### Jack truss to truncated girder truss.

**Top Chord** - Station 2450mm to 3600mm - 1/30mm x 0.8mm G.I. looped strap bent under the horizontal top chord, fixed with 4/30mm x 2.8Ø reinforced-head nails to each leg.

**Bottom Chord** - 1/Multi Grip with 4/2.8Ø nails into each side of each bottom chord

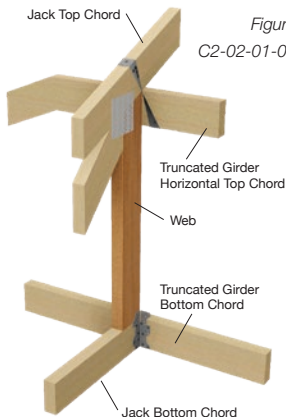

Figure  
C2-02-01-04

CHECK:  (Tick)

### Detail C2

#### Top chord to truncated standard trusses.

One framing anchor with 4/30mm x 2.8Ø reinforced-head nails into the side of each top chord.

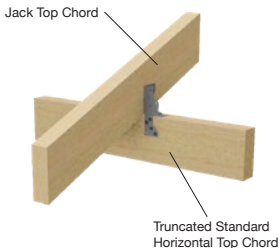

Figure C2-02-01-05

CHECK:  (Tick)

## Hip-end connection for high wind area (wind classification N4, C2 or C3)

### Detail D2

Figure C2-02-01-06

#### Creepers truss to hip truss (maximum jack station 2400mm).

**Top Chord** - one mitre plate with 6/30mm x 2.8Ø reinforced-head nails into each face.

**Bottom Chord** - one mitre plate with 6/30mm x 2.8Ø reinforced-head nails into each face.

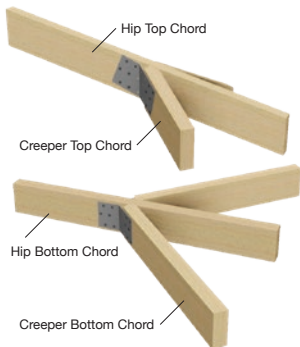

CHECK:  (Tick)

### Detail E2

Figure C2-02-01-07

#### Creepers truss to hip truss (maximum jack station 3000mm).

**Top Chord** - 1/30mm x 0.8mm G.I. looped strap with 4/30mm x 2.8Ø reinforced-head nails to each leg and one mitre plate with 6/30mm x 2.8Ø reinforced-head nails into each face.

**Bottom Chord** - one mitre plate with 6/30mm x 2.8Ø reinforced-head nails into each face.

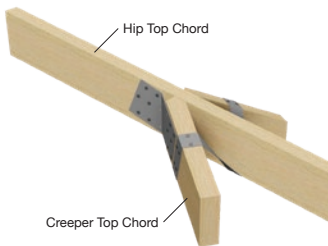

CHECK:  (Tick)

## 10.3 Valley (saddle) trusses

### 10.3.1 Valley truss connection for low wind (design wind speed N1, N2, N3 or C1)

Connection of valley trusses to the supporting truss for a low wind area shall be in accordance with the details shown and described.

**Roof pitch  $\leq 15^\circ$**  - one effective 75mm x 3.05 $\varnothing$  nail through bottom chord of valley truss into top chord of supporting truss at each intersection of the trusses.

Figure C3-01-01-03

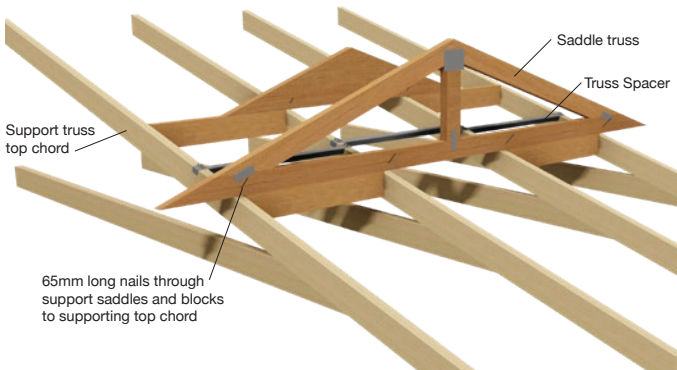

CHECK:  (Tick)

**Roof pitch > 15°** - one effective 65mm skew nail through bottom chord of valley truss into top chord of supporting truss at each intersection of the trusses, plus one 35mm x 45mm minimum timber block nailed to supporting truss top chord with one 75mm x 3.05Ø nail or one framing anchor without timber block.

Figure C3-01-01-04

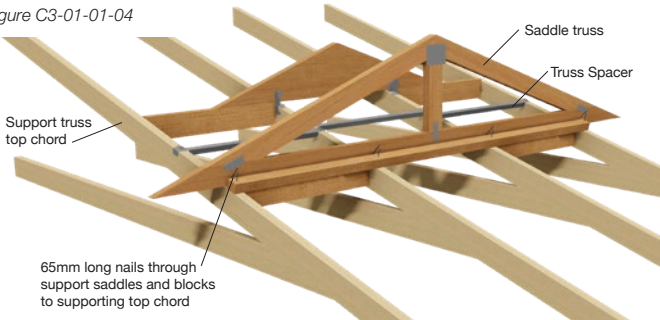

CHECK:  (Tick)

**Block infill** - (minimum of 70mm x 35mm) to where the valley truss is cantilevered more than 450mm or where the valley truss is not supported by two truss top chords, fixed to the valley truss bottom chord with 2/75mm x 3.05Ø nails, and each end to supporting truss top chord with 2/75mm x 3.05Ø nails.

Figure C3-01-01-05

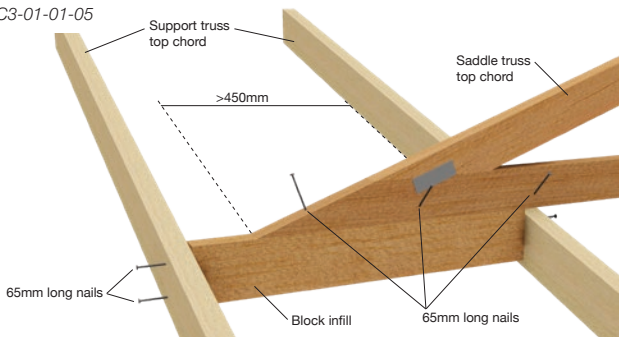

CHECK:  (Tick)

### 10.3.2 Valley truss connection for high wind (design wind speed N4, C2 or C3)

Connection of valley trusses to the supporting truss for high wind area shall be in accordance with the details shown and described.

**Supporting trusses with a ceiling** - one framing anchor with 4/30mm x 2.8Ø reinforced-head nails to each face.

Figure C3-01-02-02

Where truss spacing greater than roof batten centres, intermediate TC ties shall be required to overlap the existing battens

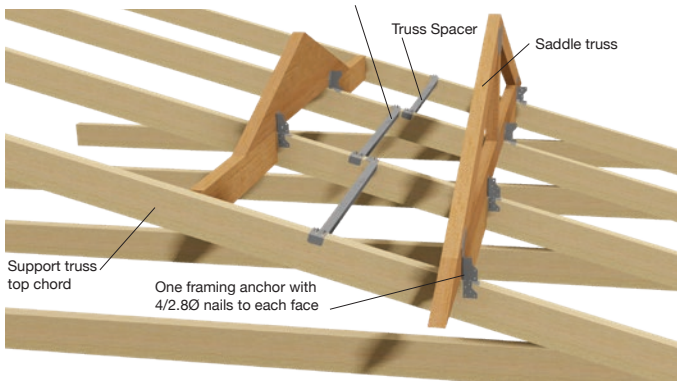

CHECK:

(Tick)

## Supporting Trusses Without a Ceiling - two framing anchors with 4/30mm x 2.8Ø reinforced-head nails to each face.

Figure C3-01-01-03

Where truss spacing greater than roof batten centres, intermediate TC ties shall be required to overlap the existing battens

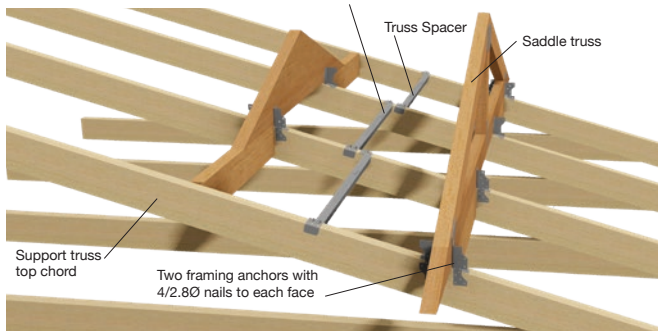

CHECK:  (Tick)

**Block infill** - (minimum of 70mm x 35mm) to where the valley truss is cantilevered more than 450mm or where the valley truss is not supported by two truss bottom chord with 2/75mm x 3.05Ø nails, and to each end of supporting truss top chord with 2/75mm x 3.05Ø nails.

Figure C3-01-01-05

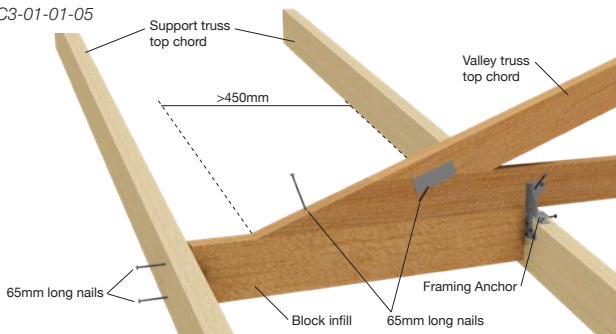

CHECK:  (Tick)

## 10.4 Gable Truss with Outrigger Positioning

### Gable truss with outrigger positioning

Figure C4-02-01-01

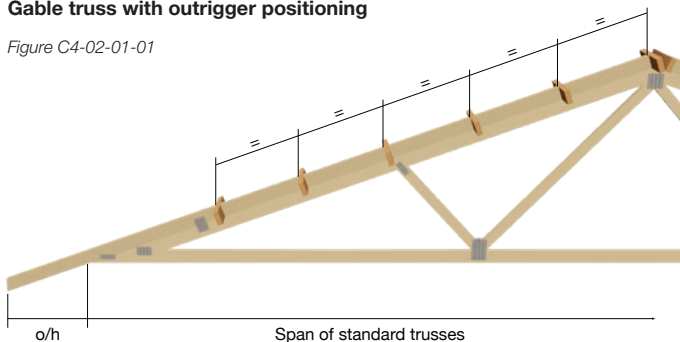

### Gable truss overhang fixing, Multinail heel positioning & first outrigger position.

Figure C4-02-01-02

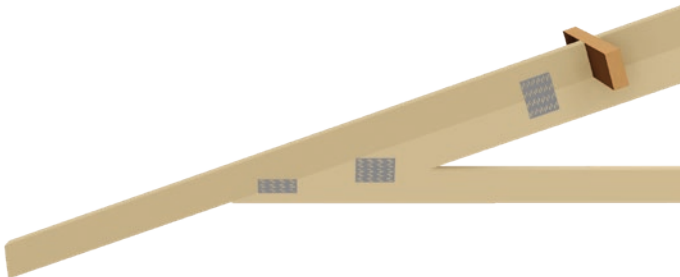

### Gable truss positioning in relation to end wall

Figure C4-02-01-03

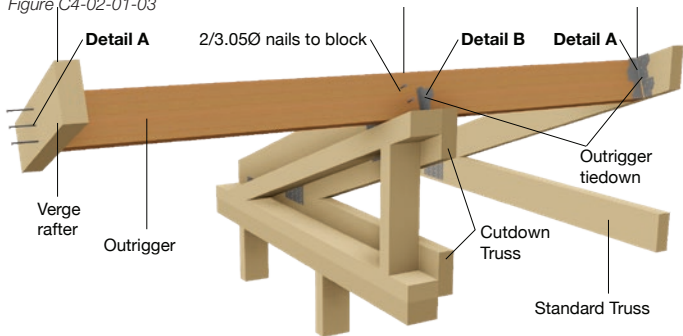

#### Very Low Wind Speed (N1 & N2)

**Detail A** - 3/75mm 3.05Ø Nails or 1/Multi Grip

**Detail B** - 2/75mm 3.05Ø skew nails

**Notes:** - Max verge overhang 600mm - Max outrigger/truss centres 600mm

#### Low Wind Speed (N2,N3 & C1)

**Detail A** - 3/75mm 3.05Ø Nails or 1/Multi Grip

**Detail B** - 1/Multi Grip or Cyclone tie

**Notes:** - Max verge overhang 1200mm - Max outrigger/truss centres 1200mm

#### High Wind Speed (N4,C2 & C3)

**Detail A** - 2/No14 Type 17 batten screws or 1/Multi Grip

**Detail B** - 1/Cyclone tie

**Notes:** - Max verge overhang 1200mm - Max outrigger/truss centres 1200mm



## 10.5 Nail-Gun edge distances

Gun-Nails are not to be driven at excessively high pressure, as they may punch through the steel product. Nail heads should be flush with the metal surface.

Care must be taken when using Nail-Gun driven nails through metal products. Refer to the Nail-Gun supplier's safety recommendations before operating these tools. Items to consider include safety clothing, eye protection and the angle of the nail to the metal should be 90°.

Multinail does not accept any responsibility for injuries incurred, if Nail-guns are used for installing Multinail metal products.

Refer to product brochure for more details include capacities.



### Important Notes:

All nails need to be 32mm long x 2.5Ø hardened screw shank nails and comply to AS2334-1980 or ASTM F1667-15.

## Cyclone Tie

Nail-Gun driven nails are to be more than 5mm from any metal edge or hole and spaced minimum 15mm apart across the grain with 10mm timber edge distance

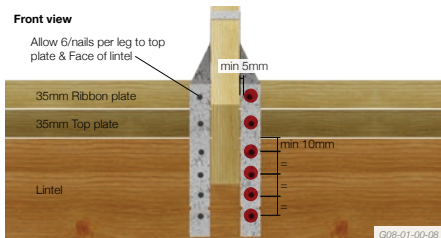
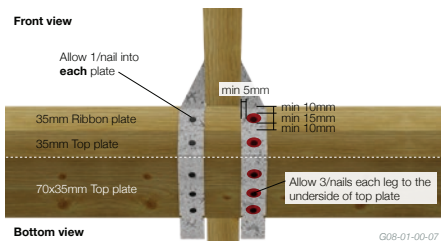

## Uni Tie

4/gun-nails into each truss and 2/nails into each top plate

(4/nails in total to top plates or beams),

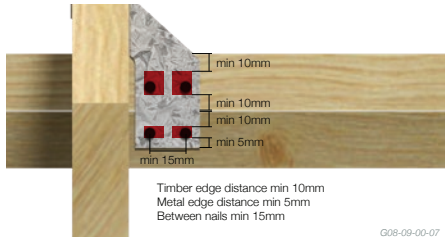

G08-09-00-07

## Stud Strap

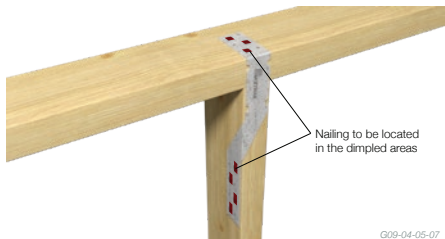

G09-04-05-07

## Joist Hanger

Multinail Joist Hanger secured to single girder truss using gun-nails

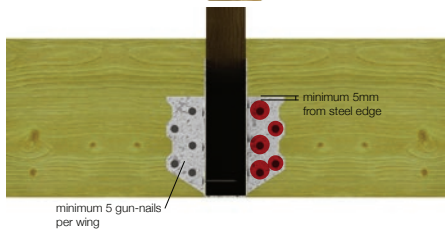

G07-04-00-06

## Flat Tension Bracing

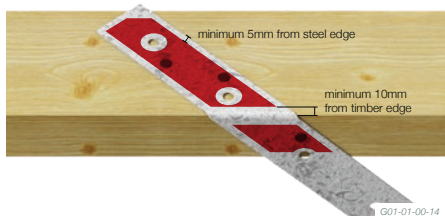

G01-01-00-14

## 10.6 Truss boot installation

Various types of truss boots can be used to form truss to truss connections. The particular boot to be used is specified by the truss fabricator for each individual joint.

### Important Notes:



1. It is essential that all appropriate bolts, washers and bracing are installed correctly into close-fitting holes as soon as the truss is erected. Damage to personnel, the trusses, the truss boot or ceiling linings may result from partial installation.
2. Do not use reduced shank or cuphead bolts.
3. For bracket capacities and connection details refer to the relevant product brochure.

### High Load Truss Boot

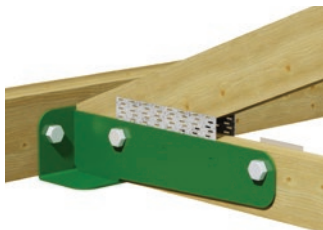

### Multi Girder Bracket



### Easy Fix Girder Bracket

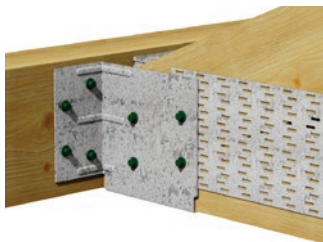

### High Load Easy Fix Girder Bracket



## 11. Waling plate fixing details to dutch hip girders

The recommendations for waling plate depth and fixing methods have been determined based on the following criteria:

- Maximum dutch hip girder station 3600mm.
- Maximum roof pitch 35 degrees.
- Maximum truss centres 1200mm.
- Jack truss overhang plus cantilever not exceeding jack truss back span.
- Girder and waling plate to be designed using Multinail Software with a web layout similar to that selected from the following table.
- Minimum waling plate thickness to be 35mm.

Truss web layout	Maximum truss span (mm)
Queenpost	5000
A Type	8500
B Type	12000
C Type	16000

### NOTES

1. The fixing method of the waling plate to the dutch hip girder will generally determine the waling plate depth. Refer to Tables 1, 2, 3 or 4 to select the waling plate depth and fixing details.
2. The truss chords **MUST** be a minimum of 90mm deep and webs a minimum of 70mm deep **UNLESS** noted otherwise in the following fixing recommendations.
3. Joint groups as shown are for **BOTH** waling plate and truss members.
4. Engineering fixings may be individually designed for other specific cases.
5. Truss webbing types and span limits above relate to the fixing of waling plates only and does not refer to the maximum load carrying capacity of the truss itself.

Figure C2-03-01-13

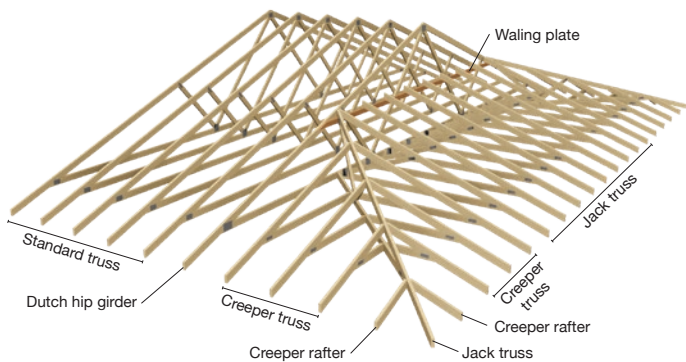

**TABLE 1: Wind speed N1, N2 ,N3**

DHG station (mm)	Steel sheet roof		Concrete tile roof	
	Waling plate depth	Fixing to chords and webs	Waling plate depth	Fixing to chords and webs
1800	90	3 Nails 1/MNGT 1/MNBT 1/M10	90	3 Nails 1/MNGT 1/MNBT 1/M10
2400	120	4 Nails 1/MNGT	120	4 Nails
	90	1/MNBT	120	2/MNGT
	90	1/M10	90	2/MNBT 1/M12
3000	120	4 Nails	140	3/MNGT
	120	2/MNGT	120	2/MNBT
	90	1/MNBT	140	2/M12
	90	1/M10	140	1/M16
3600	120	2/MNGT	140	3/MNBT 2/M12
	120	2/MNBT		
	90	1/M12		

**TABLE 2: Wind speed N4, C1**

DHG station (mm)	Steel sheet roof		Concrete tile roof	
	Waling plate depth	Fixing to chords and webs	Waling plate depth	Fixing to chords and webs
1800	90	1/MNGT 1/MNBT 1/M10	90	3 Nails 1/MNGT 1/MNBT 1/M10
2400	120	2/MNGT	120	2/MNGT
	120	2/MNBT	120	2/MNBT
	90	1/M12	90	1/M12
3000	120	2/MNGT	140	3/MNGT
	120	2/MNBT	120	2/MNBT
	90	1/M12	140	2/M12
			140	1/M16
3600	140	3/MNGT 3/MNBT 2/M12	140	3/MNBT 2/M12

**TABLE 3: Wind speed C2**

DHG station (mm)	Steel sheet roof		Concrete tile roof	
	Waling plate depth	Fixing to chords and webs	Waling plate depth	Fixing to chords and webs
1800	120	2/MNGT	90	1/MNGT
	90	1/MNBT		1/MNBT
	90	1/M10		1/M10
2400	120	2/MNGT	120	2/MNGT
	120	2/MNBT	120	2/MNBT
	140	2/M12	90	1/M12
3000	140	3/MNGT	140	3/MNGT
		3/MNBT	120	2/MNBT
		2/M12	140	2/M12
			140	1/M16
3600	140	2/M12	140	3/MNBT 2/M12

**TABLE 4: Wind speed C3**

DHG station (mm)	Steel sheet roof		Concrete tile roof	
	Waling plate depth	Fixing to chords and webs	Waling plate depth	Fixing to chords and webs
1800	120	2/MNGT	90	1/MNGT
	120	2/MNBT		1/MNBT
	90	1/M12		1/M10
2400	140	3/MNGT	140	3/MNGT
		3/MNBT		3/MNBT
		2/M12		2/M12
3000	190	3/M12	140	2/M12
3600	190	3/M12	190	3/M12
		2/M16		2/M16

**Legend**

MNGT	Multinail Green Tip Screw
MNBT	Multinail Black Tip Screw
M10	10Ø Bolt
M12	12Ø Bolt
M16	16Ø Bolt

### Waling plate fixed with 3/75mm x 3.05 Ø nails per member.

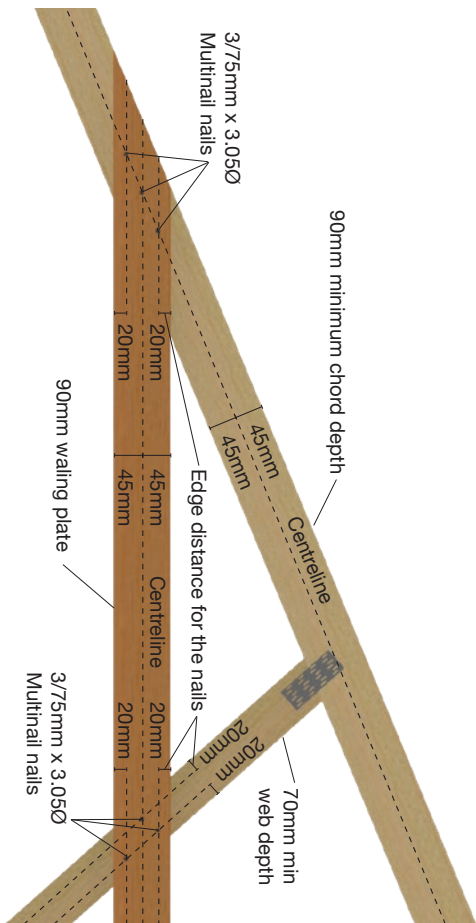

Figure C2-03-01-12



**Waling plate fixed with 3/75mm x 3.05 Ø nails per member.**

Figure C2-03-01-02

**Waling plate fixed with 4/75mm x 3.05 Ø nails per member.**

Figure C2-03-01-04

**Waling plate fixed with 6/75mm x 3.05 Ø nails per member.**

Figure C2-03-01-03

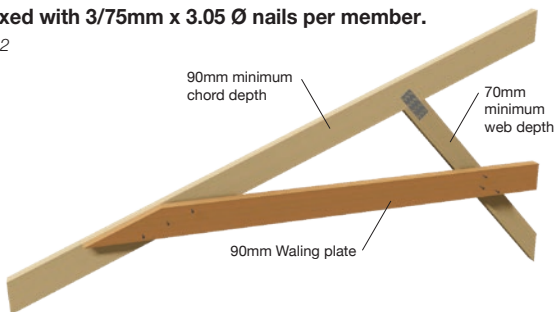

	Multinail Green Tip Screws D=5.6mm	Multinail Black Tip Screws D=6.3 mm
End distance 10D	56mm	63mm
Edge distance 5D	28mm	32mm
Spacing along grain 10D	56mm	63mm
Spacing across grain 3D	17mm	19mm

### 2/MNGT or 2/MNBT with 90mm web and 90mm Waling plate

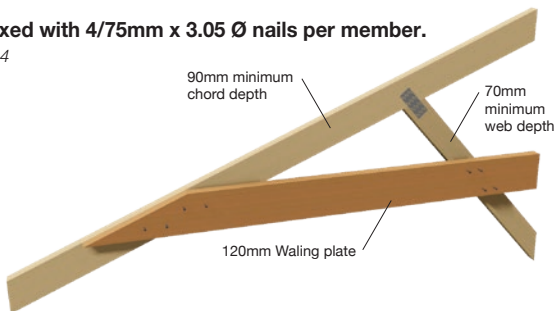
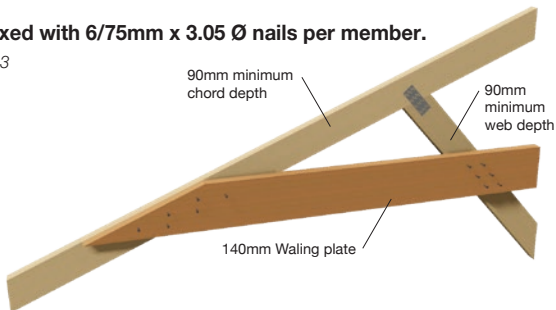
Figure C2-03-01-07

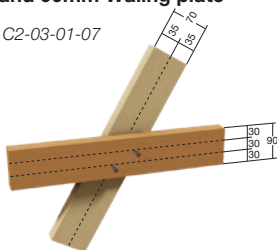

### 2/MNGT or 2/MNBT with 70mm web and 120mm Waling plate

Figure C2-03-01-08

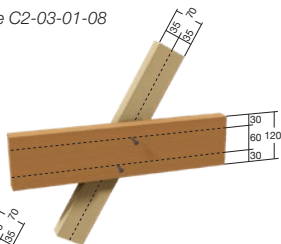

### 3/MNGT or 3/MNBT with 70mm web and 140mm Waling plate

Figure C2-03-01-09

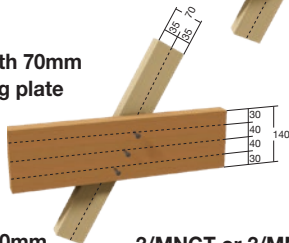

### 2/MNGT or 2/MNBT 120mm Waling plate

Figure C2-03-01-10

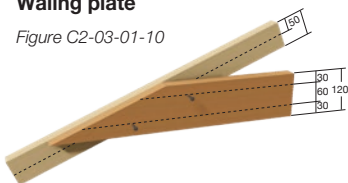

### 3/MNGT or 3/MNBT 140mm Waling plate

Figure C2-03-01-11

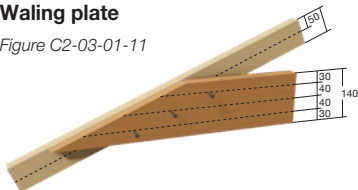

## Waling plate fixed with one bolt per member.

Figure C2-03-01-05

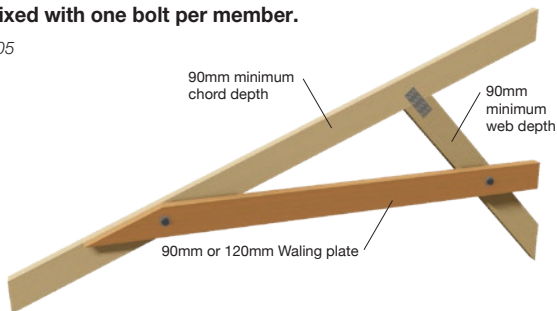

## Waling plate fixed with two bolt per member.

Figure C2-03-01-06

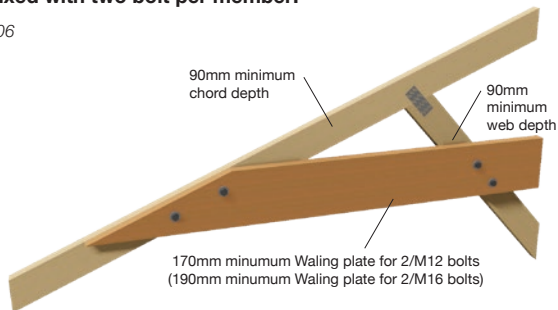

### Washers required for bolts as per AS1720.1

Bolt dia.	Thickness	Circular washer	Square washer
M10	2.5mm	45mm	40mm
M12	3.0mm	55mm	50mm
M16	4.0mm	65mm	57mm

## 12. Roof battens

The size, spacing and fixing of roof battens or purlins shall be in accordance with the relevant code approved specifications. The batten and fixing must have adequate strength to laterally restrain the roof trusses. Fix each batten to every lamination of every truss.

In addition to providing support to the roof cladding, roof battens prevent truss top chords from buckling. The buckling action is due to the compressive force in the top chord of the roof truss. The roof battens resist the roof trusses which in turn transfers it to the steel roof bracing and down to the supporting structure. Each element and fixing in the sequence is essential for roof structure stability.

In areas where battens or purlins are not bound on both sides by diagonal bracing, battens shall be continuous (see Figure C1-04-01-01).

Where required, splices in battens shall be arranged so no more than one-third of battens are spliced and no two splices are adjacent in any top chord.

For more information, refer to Multinail Technical recommendations for Roof Battens.

**Important note:** DO NOT splice roof battens on girder trusses.

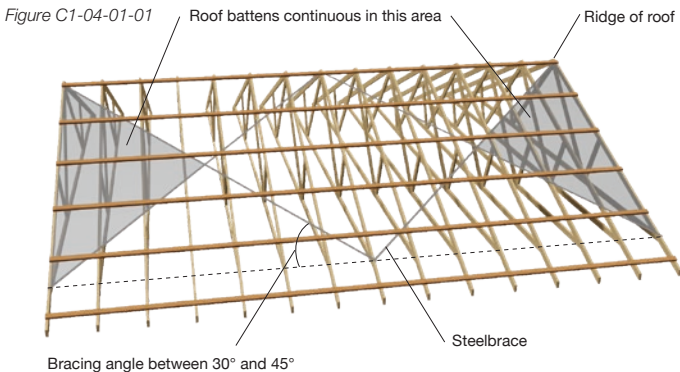

CHECK:

(Tick)

## 12.1 Roof batten splicing

The following roof batten splicing details are recommended to adequately provide lateral restraint to the roof truss top chords for all metal sheet roofs.

Batten tie down and size to be designed by others

Rules given in AS4440 must also be followed which include:

- Do not splice battens on girder trusses
- Fix each batten to every lamination of every truss with minimum 2/nails
- Adjacent battens should not be spliced in the same point
- Not more than 1 in 3 battens to be spliced on any truss top chord

Design criteria	
Roof material	Steel Sheeting
Truss centres	1200mm maximum
Batten size	35 x 70 min. 45 x 90 maximum
Batten spacing	1200mm maximum

### Option 1

Figure C1-04-02-01

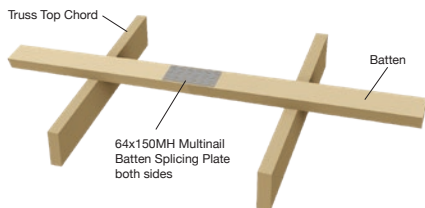

Splice plates must be located centrally on the batten and centrally across the joint. Splices may be located anywhere along the batten.

### Option 2

Figure C1-04-02-02

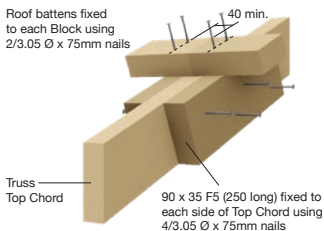

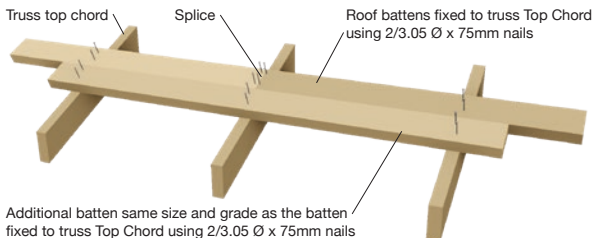
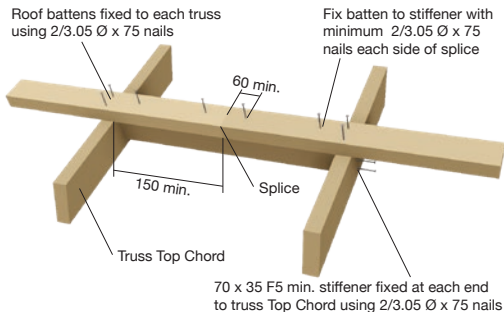
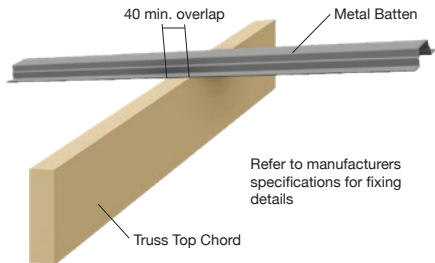
**Option 3** *Figure C1-04-02-03***Option 4***Figure C1-04-02-04***Option 5***Figure C1-04-02-05*

## 13. Top chord bracing

The requirement for a top chord bracing system is to transfer forces generated in the top chord restraints (usually roof battens or purlins) back to the supporting structure.

The forces are generated by resisting buckling of the top chord members and by wind loading perpendicular to the span of the trusses.

**CHECK APPROPRIATE BRACING LAYOUT USED:**  (Tick)

For more information on specific roof shapes, refer to AS4440.

### 13.1 Steelbrace for gable roof

The type and layout of the top chord steelbrace relate to the span, shape and loading of the roof.

The angle from steelbrace to wall frame shall be between 30° and 45°.

Bracing bays shall extend from the end trusses of the roof, unless otherwise specified in this Standard.

The area of the standard overhangs is not required to be braced.

In following Figures, length (L) and half span (h) are defined as follows:

**Length (L)** - the length of run of similar trusses with similar support positions. However, where adjoining sections of the roof have trusses running parallel to the trusses in the section being considered and where the top chords are in the same plane, Length (L) may be extended into the adjoining section, provided that the trusses have common support positions (see Figure C5-04-02-01).

## Length (L) and Half span (h)

The horizontal distance from the pitching point to the point at which the top pitch changes.

Figure C5-04-02-01

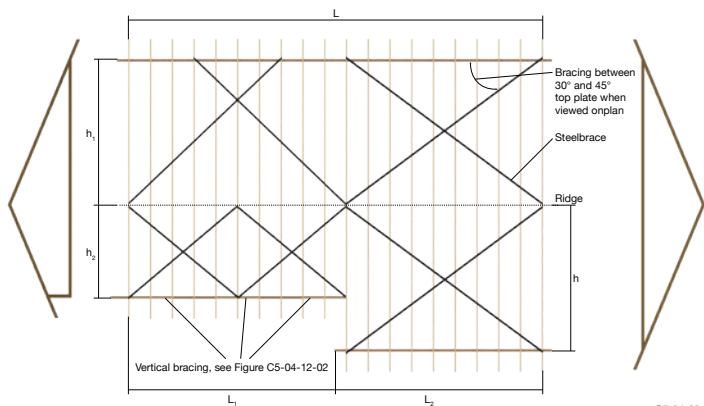

C5-04-02-01

Figure C5-04-02-02

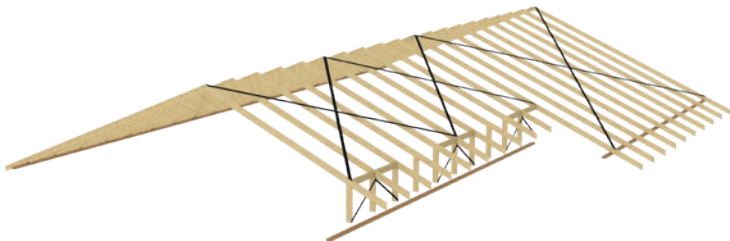

C5-04-02-02



### 13.2 Spans up to 8m

For spans up to 8m, the single steelbrace shall be arranged in a V-shape configuration. Each truss in the brace section shall be crossed with at least two braces.

The top chord steelbrace shall be arranged according to the following roof lengths:

#### Roof length (L) less than half span (h).

See section 13.3 and Figure C5-04-04-02.

#### Very short roof

Where the roof Length (L) is 1 to 1.5 times the half span (h) of the roof truss, the steelbrace shall be arranged as shown.

#### Steelbrace layout roof, spans up to 8m

Figure C5-04-03-01

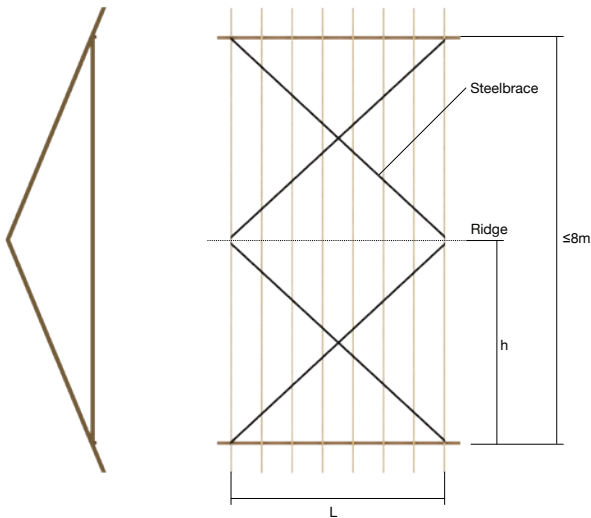

C5-04-03-01

## Steelbrace layout for short roof, spans up to 8m

Where the roof Length (L) is 1.5 to 3.5 times the half span (h) of the roof truss, the steelbrace shall be arranged as shown.

Figure C5-04-03-02

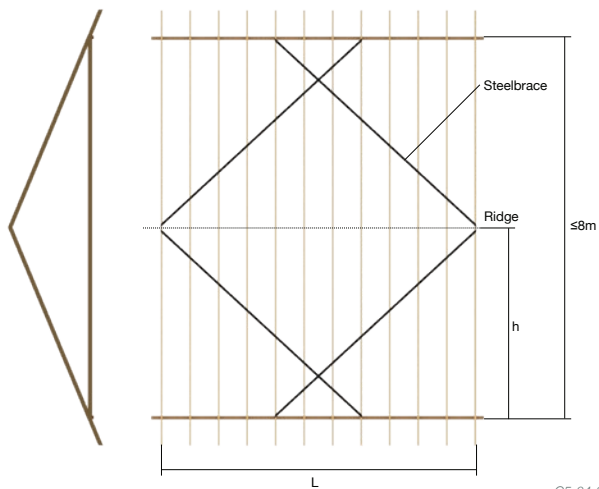

C5-04-03-02

Figure C5-04-03-06

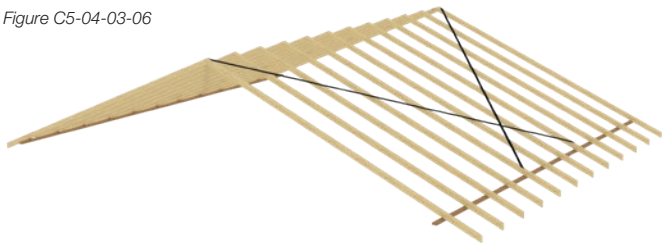

C5-04-03-06

### Steelbrace layout for long roof, spans up to 8m

Where the roof Length ( $L$ ) is 3.5 to 4 times the half span ( $h$ ) of the roof truss, the steelbrace shall be arranged as shown.

Figure C5-04-03-03

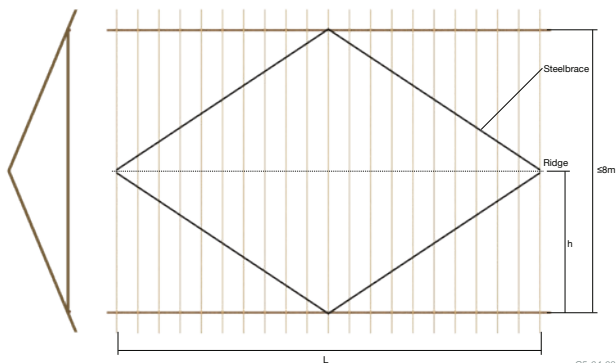

### Steelbrace layout for very long roof, spans up to 8m

Where the roof Length ( $L$ ) is more than 4 times the half span ( $h$ ) of the roof truss, the steelbrace shall be arranged as shown.

Figure C5-04-03-04

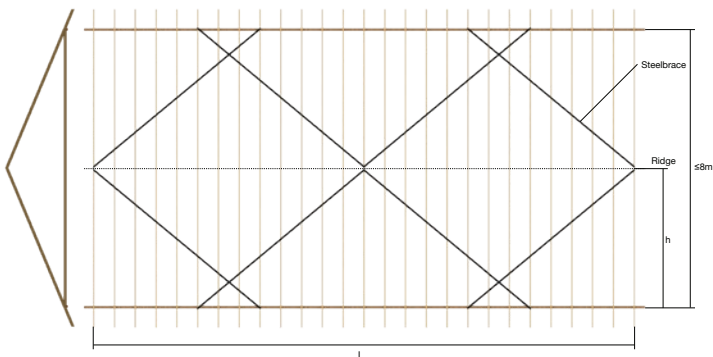

### 13.3 Spans of 8m to 13m

For spans of 8m to 13m, a steelbrace in an X-shape configuration shall be used.

A single steelbrace shall be used with the limitation in the span of roof trusses as specified in Table below.

Each truss in the brace section shall be crossed with at least four braces.

For a roof with overall span greater than the maximum values specified in Table 1 but less than 13.0m, a double steelbrace shall be used, as shown.

#### Maximum overall truss span for single steelbrace (in metres)

Wind classification	Roof pitch <math><15^\circ</math>	Roof pitch <math&gt;15^\circ&lt; math=""> to <math&gt;20^\circ&lt; math&gt;<="" th=""> <th>Roof pitch <math&gt;20^\circ&lt; math="">+ to <math&gt;30^\circ&lt; math&gt;<="" th=""> <th>Roof pitch <math&gt;30^\circ&lt; math="">+ to <math&gt;35^\circ&lt; math&gt;<="" th=""> <th>Roof pitch <math&gt;35^\circ&lt; math="">+ to <math&gt;45^\circ&lt; math&gt;<="" th=""> </math&gt;45^\circ&lt;></math&gt;35^\circ&lt;></th></math&gt;35^\circ&lt;></math&gt;30^\circ&lt;></th></math&gt;30^\circ&lt;></math&gt;20^\circ&lt;></th></math&gt;20^\circ&lt;></math&gt;15^\circ&lt;>	Roof pitch <math&gt;20^\circ&lt; math="">+ to <math&gt;30^\circ&lt; math&gt;<="" th=""> <th>Roof pitch <math&gt;30^\circ&lt; math="">+ to <math&gt;35^\circ&lt; math&gt;<="" th=""> <th>Roof pitch <math&gt;35^\circ&lt; math="">+ to <math&gt;45^\circ&lt; math&gt;<="" th=""> </math&gt;45^\circ&lt;></math&gt;35^\circ&lt;></th></math&gt;35^\circ&lt;></math&gt;30^\circ&lt;></th></math&gt;30^\circ&lt;></math&gt;20^\circ&lt;>	Roof pitch <math&gt;30^\circ&lt; math="">+ to <math&gt;35^\circ&lt; math&gt;<="" th=""> <th>Roof pitch <math&gt;35^\circ&lt; math="">+ to <math&gt;45^\circ&lt; math&gt;<="" th=""> </math&gt;45^\circ&lt;></math&gt;35^\circ&lt;></th></math&gt;35^\circ&lt;></math&gt;30^\circ&lt;>	Roof pitch <math&gt;35^\circ&lt; math="">+ to <math&gt;45^\circ&lt; math&gt;<="" th=""> </math&gt;45^\circ&lt;></math&gt;35^\circ&lt;>
N1-N3, C1	13.0	13.0	12.5	11.5	9.5
up to N4, C2	13.0	13.0	10.5	9.5	8.0
C3	12.0	11.0	8.5	Not suitable	Not suitable

Figure C5-04-04-06

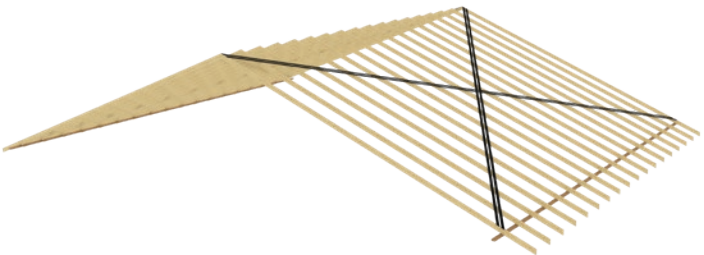

C5-04-04-06

The top chord steelbrace for spans of 8m to 13m shall be arranged according to the following roof lengths:

### Steelbrace layout for very short roof, spans 8m to 13m

Where the roof Length (L) is very short compared to the half span (h) of the roof truss such that it would result in a brace angle greater than  $45^\circ$ , a diagonal steelbrace arrangement shall be required each side of the ridge line as shown. Bracing bays shall be spaced across the roof such that the brace angle is always between  $30^\circ$  and  $45^\circ$ .

Figure C5-04-04-02

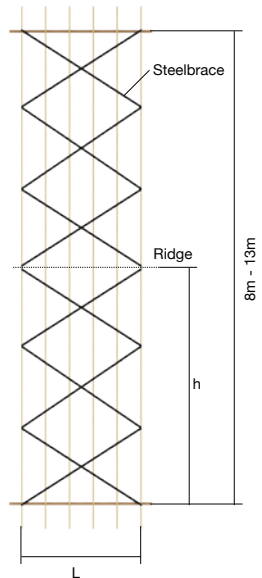

Figure C5-04-04-07



C5-04-04-07

## Steelbrace layout for short roof, spans 8m to 13m

Where the roof Length (L) is 1.5 to 3.5 times the half span (h) of the roof truss, the steelbrace shall be arranged as shown.

Figure C5-04-04-03

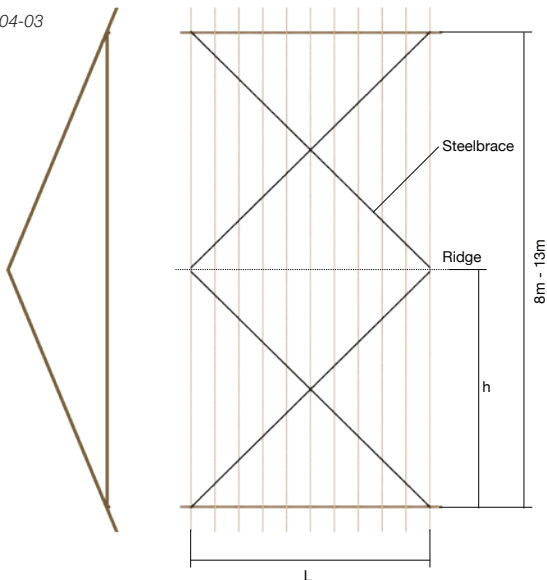
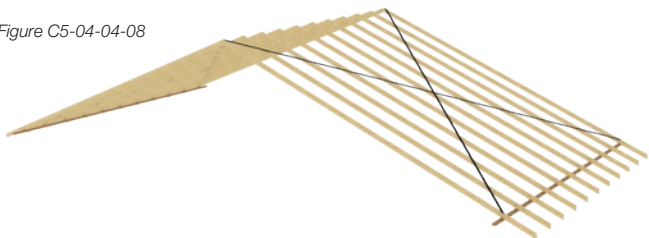

Figure C5-04-04-08



C5-04-04-08

### Steelbrace layout for long roof, spans 8m to 13m

Where the roof Length (L) is long compared to the half span (h) of the roof truss such that it would result in a brace angle less than  $30^\circ$ , two or more crossed bracing bays shall be required each side of the ridge line to ensure the brace angle is between  $30^\circ$  and  $45^\circ$  (See Figure C5-04-04)

Figure C5-04-04-04

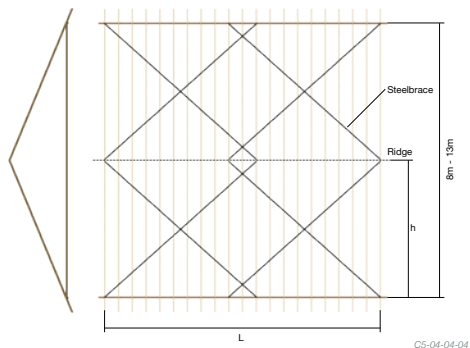

### Steelbrace layout for very long roof, spans 8m to 13m

For a very long roof the steelbrace is continued for the length of building such that each truss shall be crossed with at least four braces (see Figure C5-04-04-05).

Figure C5-04-04-05

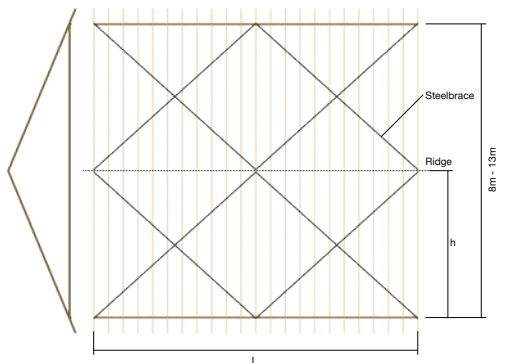

### 13.4 Spans of 13m to 16m

For truss spans of 13m to 16m, the steelbrace shall be in an X-shape configuration over the whole roof with an additional braced bay at each end and intermediate braced bays at maximum 13000mm centres, as shown.

#### Steelbrace layout for very long roof, spans 13m to 16m

Figure C5-04-05-01

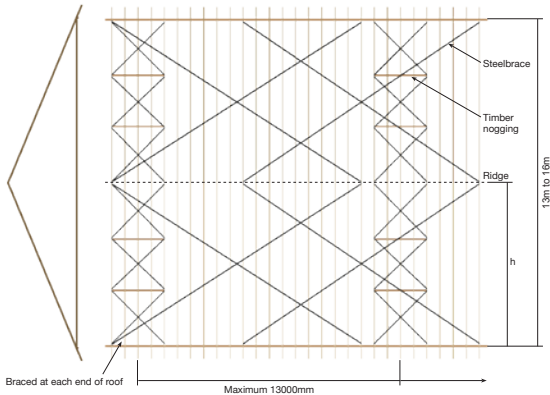

#### Maximum overall truss spans for steelbrace

Maximum overall truss span, m							
Wind	Roof Pitch						
	Single brace		Double brace				
	<15°	15°to20°	<15°	15°to20°	20°+to30°	30°+to35°	35°+to45°
N1-N3, C1	16.0	16.0	16.0	16.0	16.0	16.0	13.5
N4, C2	15.5	13.0	16.0	16.0	14.5	13.5	N/S
C3	Not suitable	Not suitable	16.0	15.5	Not suitable	Not suitable	Not suitable



## 13.5 Steelbrace for hip roof

### 13.5.1 Bracing requirement for standard trusses

For roofs on buildings of rectangular plan with trussed hip ends or dutch-hip ends, the steelbrace for standard trusses shall be required between the apex of hip ends only.

In such cases the roof Length (L) shall be taken as being the distance between the two intersections of hip and ridge line at each end of the building.

One of the criteria from section 13.2 to 13.4 shall then be applied as shown.

### Steelbrace layout for standard trusses of Hip Roof

Figure C5-04-07-01

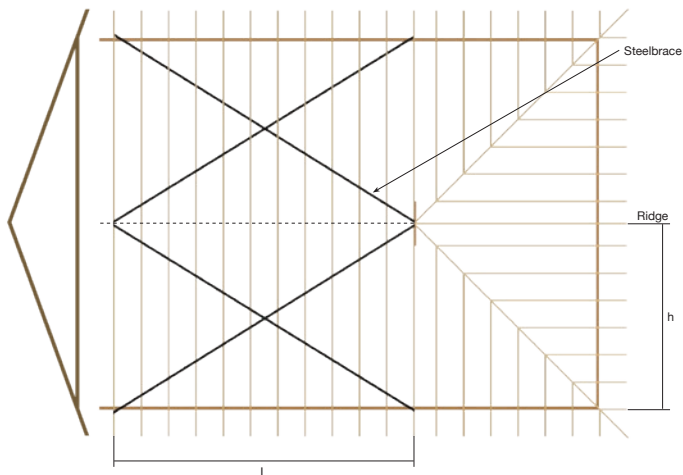

### 13.6 Bracing requirement for jack trusses

For standard roof trusses less than 13m, no bracing to jack trusses is required.

For standard truss spans of 13m to 16m, the single steelbrace shall be arranged in an X-shape configuration. The angle from steelbrace to end wall shall be between  $30^\circ$  and  $45^\circ$ .

The top chord steelbrace for jack trusses shall be arranged in accordance with the following:

Where the Horizontal Top Chord Length (HTL) is less than the Truncated Girder Station (TGS), the steelbrace shall be arranged as shown.

#### Steelbrace layout for Jack Trusses (HTL < TGS)

Figure C5-04-08-01

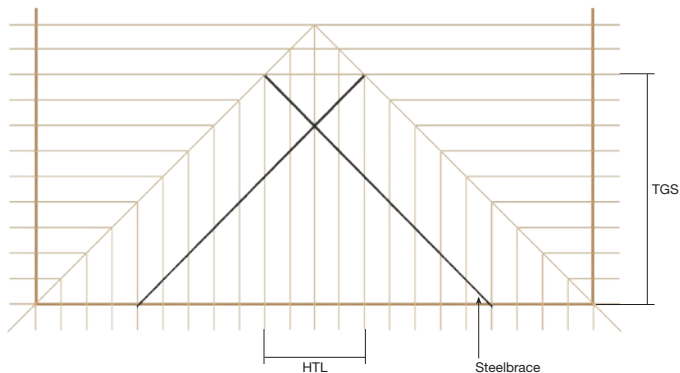
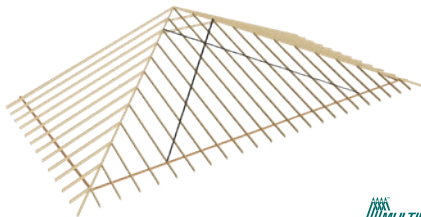

Figure C5-04-08-04



### Steelbrace layout for Jack Trusses (HTL = 1 to 1.5 TGS)

Where the Horizontal Top Chord Length (HTL) is 1 to 1.5 times the Truncated Girder Station (TGS), the steelbrace shall be arranged as shown.

Figure C5-04-08-02

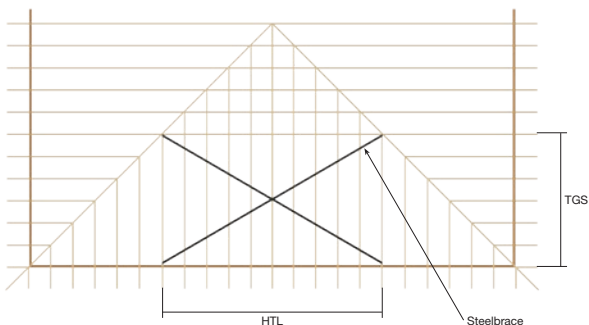

### Steelbrace layout for Jack Trusses (HTL > 1.5 x TGS)

Where the Horizontal Top Chord Length (HTL) is longer than 1.5 times the Truncated Girder Station (TGS), the steelbrace shall be arranged as shown.

Figure C5-04-08-03

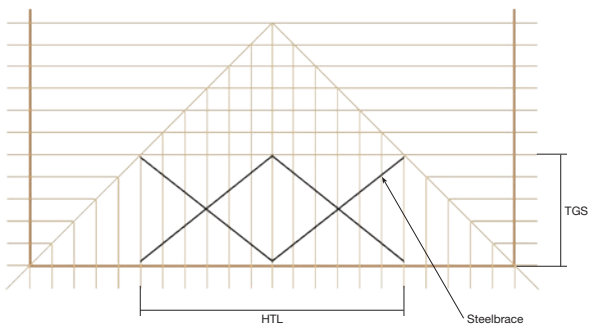

### 13.7 Steelbrace for dual-pitched roof

On dual-pitched or cutoff roofs where the ridge line is not central on the building, each side of the ridge shall be considered as a separate case.

A steelbrace layout resulting from a combination of the criteria specified in Clauses 14.2 to 14.7 shall apply.

#### Typical Steelbrace layout for Dual Pitched or cutoff roof

Figure C5-04-09-01

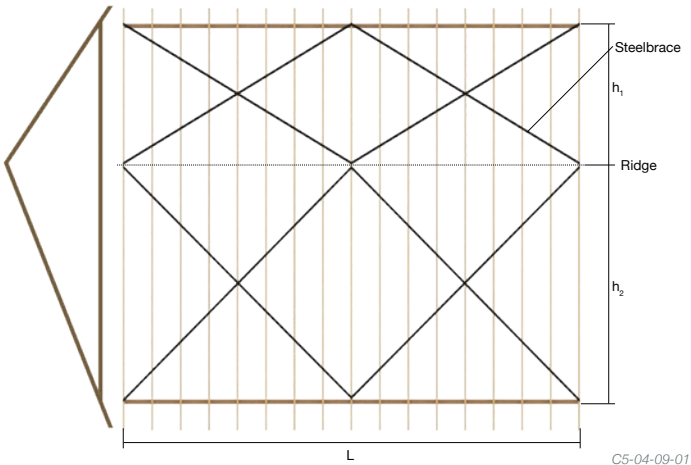
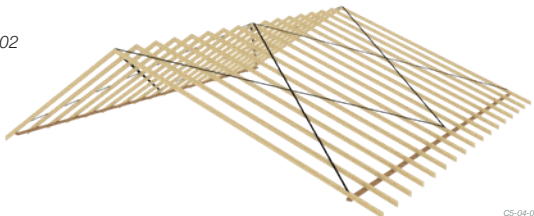

Figure C5-04-09-02



### 13.8 Steelbrace for bell roof

The steelbrace shall be spliced at bell breaks, see Figure below for splicing details.

Figure C5-04-10-01

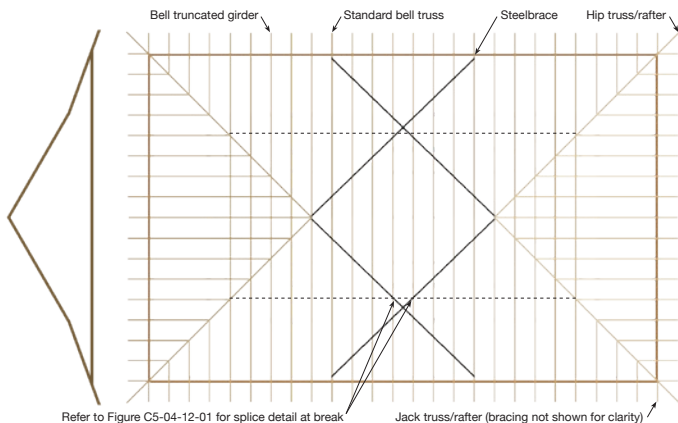
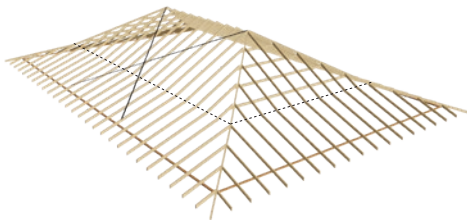

Figure C5-04-10-02



### 13.9 Steelbrace for mono-pitched roof

Where the roof consists of half trusses (mono-pitched roof), the span of the half truss shall be taken as the half span ( $h$ ), and one criterion from sections 13.2 to 134 shall be applied.

The apex of the half truss shall be braced to the supporting structure with diagonal bracing in the vertical plane as specified for half truss fixing for apex bracing in Figure C5-04-12-08 and Figure C5-04-12-09.

### 13.10 Fixing of steelbrace

The steelbrace shall be arranged in a V-shape or X-shape configuration over the top of the top chords as specified in the bracing layouts in Clauses 13.2 to 13.4. Steelbrace shall be fixed to each truss in the brace section and to the supports, using a minimum of 30mm x 2.8Ø reinforced-head nails in accordance with the following details:

#### Typical Spliced Detail

Figure C5-04-12-01

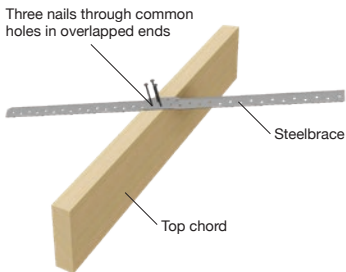
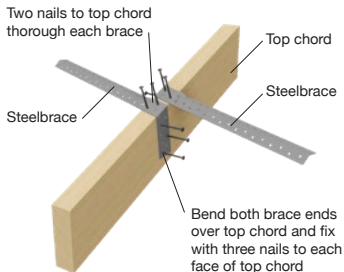

Figure C5-04-12-02



CHECK:  (Tick)

#### End Fixing Details at Apex

Figure C5-04-12-03

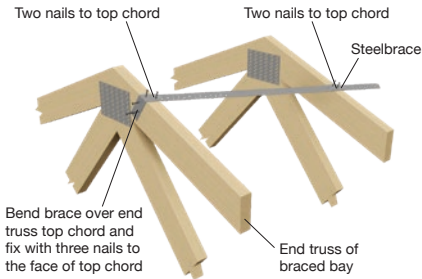

CHECK:  (Tick)

## End Fixing Details at Heel, to Top Plate

Figure C5-04-12-04

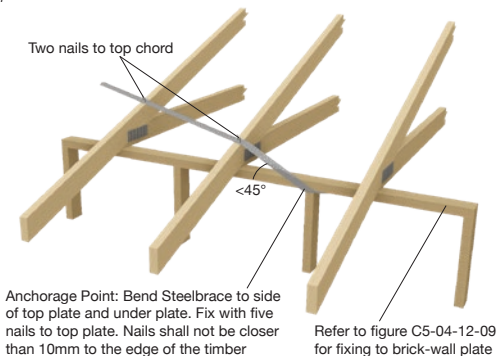

CHECK:  (Tick)

## End Fixing Details at Heel, to Top Plate (alternative)

Figure C5-04-12-05

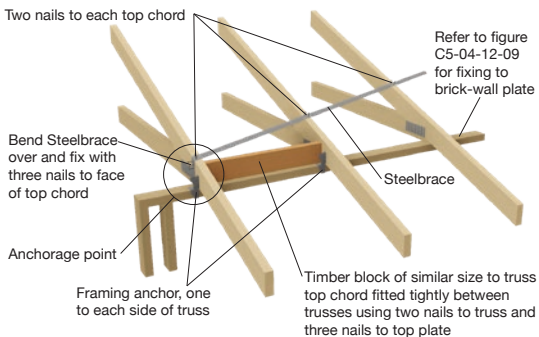

CHECK:  (Tick)

## End Fixing Details at Heel, to Girder Truss

Figure C5-04-12-06

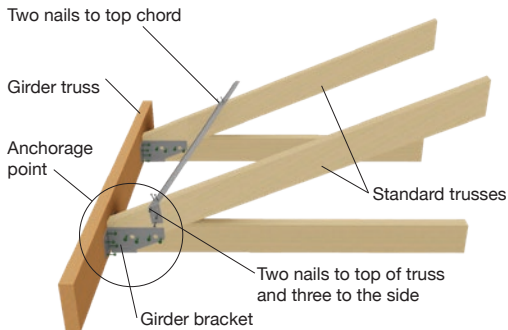

CHECK:  (Tick)

## Fixing Details for Cantilevers

Figure C5-04-12-07

Timber block of similar size to truss top chord fitted tightly between trusses. Use two nails to fix to each truss and three nails to fix to top plate

Refer to Figure C5-04-12-03 for end fixing details

Steelbrace continuous to truss heel

Two nails to top chord

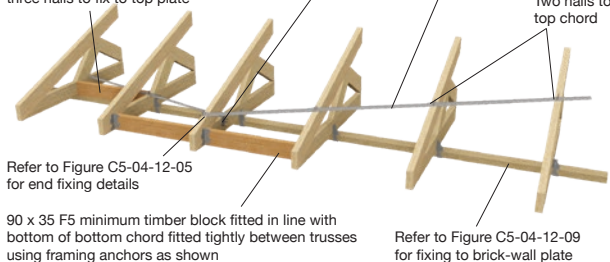

CHECK:  (Tick)



## Fixing Details for Cut-off or Half Trusses

Figure C5-04-12-08

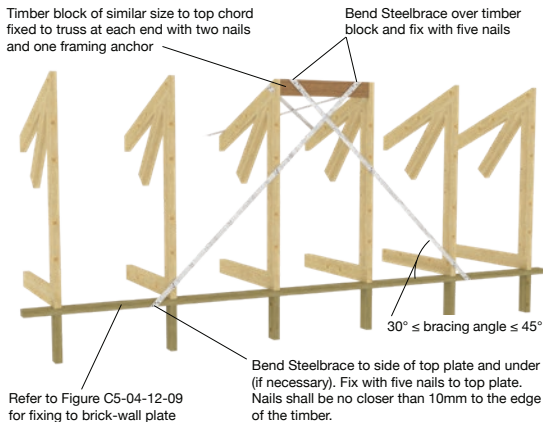

CHECK:  (Tick)

## Fixing Details for Brick-wall Plate

Figure C5-04-12-09

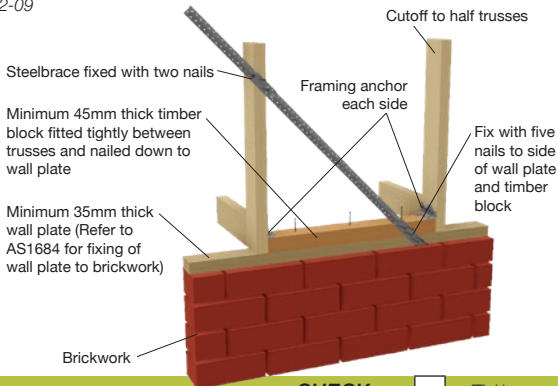

CHECK:  (Tick)

## 14. Bottom chord bracing

A permanent bottom chord bracing system is required to restrain truss bottom chords against lateral buckling under wind uplift. A direct fixed or battened ceiling is generally sufficient to perform this function except as noted in section 14.2 below.

### 14.1 Ceiling battens

Batten spacing shall not exceed that specified by the approved specifications for ceiling support and bottom chord restraint centres.

### 14.2 Bottom chord ties

For suspended ceilings, or exposed bottom chords, or where ceiling battens do not provide restraint to bottom chords (e.g. metal furring channels clipped to trusses) the size and spacing of separate bottom chord ties shall comply with the approved specifications.

#### NOTES:

1. The bottom chord ties are not intended to replace the binders required to support the end wall.
2. The bottom chord ties and bracing are intended only to restrain (i.e. to stop from buckling) truss bottom chords and do not provide lateral stability to the building to resist lateral wind loads.
3. Buildings with suspended ceilings require additional bracing to ensure the lateral stability of the walls. **The responsibility for the stability of the structure rests solely with the project engineer/building designer.**
4. These bottom chord ties are not designed to be a trafficable platform.

For trusses with ceiling directly fixed to truss bottom chords by glue or nails, or both, ties as temporary bracing to bottom chords are required until the ceiling is fully fixed in place. See section 7 for details.

Where bottom chord ties are required, they shall be braced or fixed to a building element such as supporting walls, which in turn can transfer these bracing loads to the structure.

Steelbrace shall be at approximately 45° to wall top plates, see Figure below, and shall be fixed to each truss and to the wall in the same manner as for top chord brace fixing.

### Typical bottom chord ties bracing layout

Figure C5-04-13-01

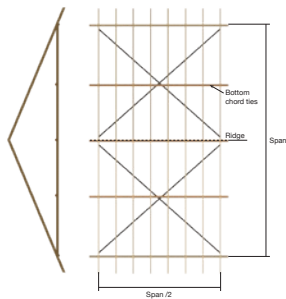

Figure C5-04-13-02

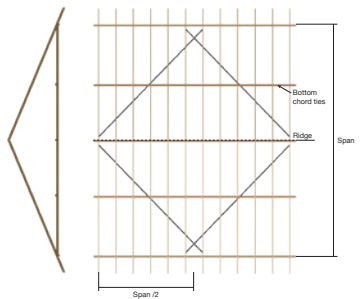

Figure C5-04-13-04

Figure C5-04-13-03



CHECK:  (Tick)

## 15. Web bracing

Where truss designs require bracing to be applied to webs, this can be achieved by the use of longitudinal ties, T-stiffeners or other supplementary members. Where longitudinal ties are used, they shall be a minimum of 70mm x 35mm F5, or as specified in the design specifications. The web ties shall be fixed to the web of each truss at even spacing of the web with two 75mm x 3.05Ø long nails and braced to the truss with one bay of crossed steelbrace at each end and an intermediate bay at 10m centres. Web ties shall be continuous or, where required, spliced by lapping over at least two adjacent trusses.

Figure C5-04-14-01

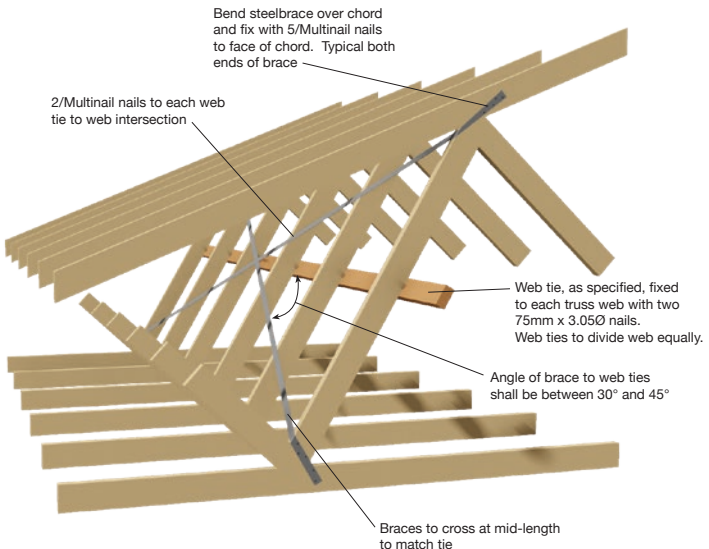

CHECK:  (Tick)

## 16. Walls

Trusses are usually designed to be supported only by the outer walls of the structure with none of the loadbearing transmitted to internal walls.

The bottom chord of the truss is designed with an inbuilt camber to suit the span and load. This camber is progressively taken up as the load is applied (ie, the roofing and ceiling).

Wall frames of non-loadbearing internal walls must therefore be constructed to allow free movement of the trusses as they are loaded and unless otherwise specified a truss must not be supported at any intermediate point along its span.

### 16.1 Non-loadbearing walls

Non-loadbearing walls must comply with the requirements specified in the relevant Standards as appropriate to the material.

Non-loadbearing walls, as designated, shall not carry any truss loading and shall not be packed to touch the underside of trusses, see Figure below.

**NOTE:** One way to ensure non-loadbearing is to set the non-loadbearing walls at a lower level than the loadbearing walls. The recommended difference in level is the ceiling batten depth (if any) plus 10mm minimum.

Figure A1-03-01-02

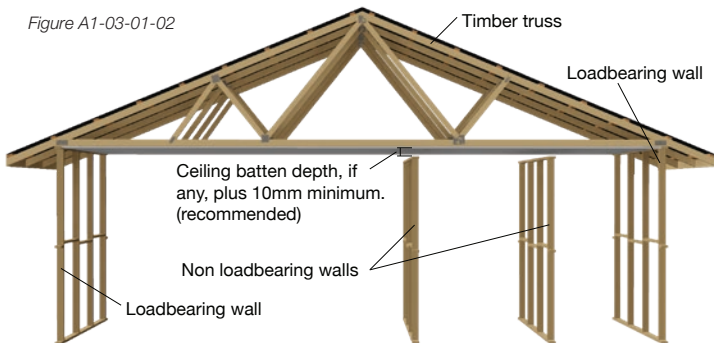

CHECK:  (Tick)

### 16.1.1 Fixing to top plates of non-loadbearing walls

The requirements for fixing of timber trusses to the top plates of non-loadbearing walls shall be in accordance with the following wall designations:

**(a) Non-bracing wall:** Where a non-loadbearing wall is stable in its own right, no stabilizing fixing is required.

**(b) Bracing wall:** Where a freestanding non-loadbearing wall is designated as a bracing unit in accordance with AS 1684.2 or AS 1684.3, the timber trusses shall be fixed to the top plate of the wall in such a way that the bottom chord of the truss is restrained horizontally but allows for deflection when the truss is loaded. Figure below gives an example of the fixing details.

#### Wall is parallel to truss

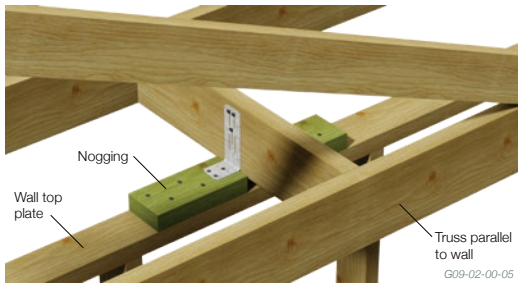

#### Wall is perpendicular to truss

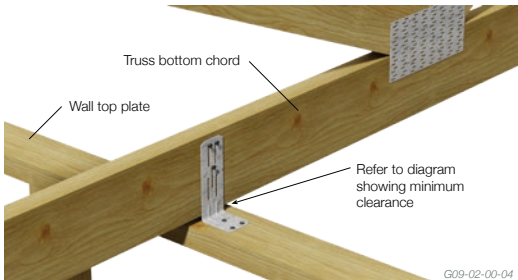

### 16.1.2 Internal wall brackets

Internal Wall Brackets are used to connect internal non-loadbearing walls to roof trusses at maximum 1800mm centres. To enable the roof truss to deflect under loads, nails to the truss must be installed at the top of the slotted holes and not hammered home to allow a loose fit only.

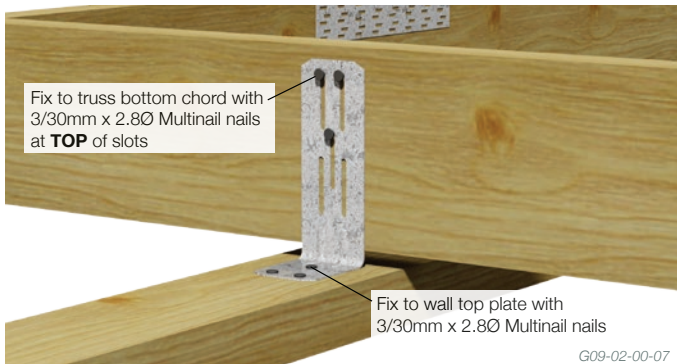

## 16.2 Loadbearing walls

Loadbearing walls must be constructed so as to support all loads from the roof structure.

Connections to loadbearing walls are generally provided with the project documentation.

Load-Bearing walls shall comply with the requirements specified in the relevant standards, as appropriate to the material, and shall not be lower than the non-loadbearing walls when trusses are supporting a level ceiling.

### 16.3 Bearing plates

Under high concentrated loads from girder truss bearing plates are used to spread the load on a top plate which reduces crushing.

#### 6mm Bearing Plate

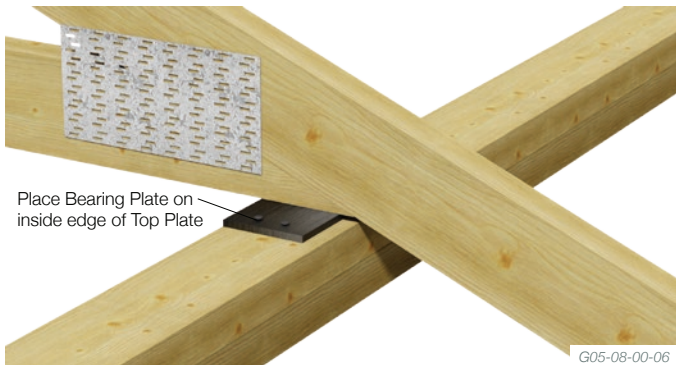



## 16.4 Steel Nogs

Lighter and easier to handle, reducing the weight of frames by removing timber nogs.

Better accessibility, making it easier to run electrical wires and plumbing in wall cavity area.

### Used in replacement of traditional timber nogs

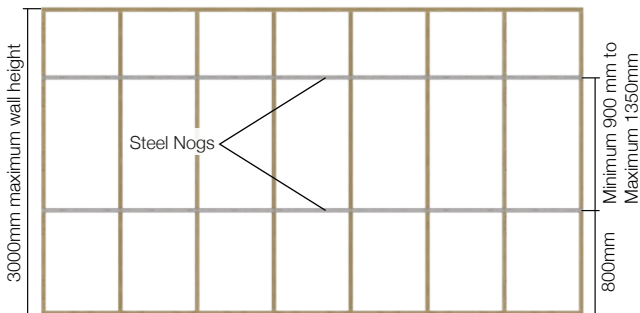

G09-07-00-03



G09-07-00-04

## Short wall bracing

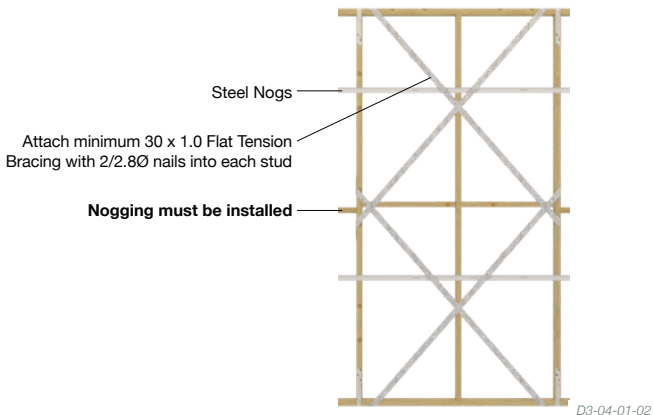

## Steel Nogs installed with flat tension bracing

Steel Nogs are allowed to be used with flat tension bracing

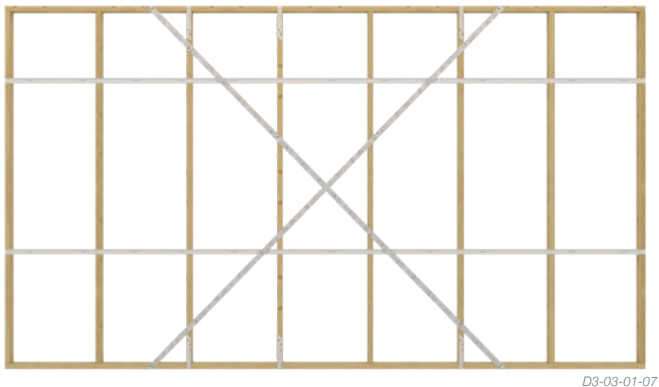

## 17. Parallel Chord Trusses

### 17.1 Correct orientation

MSJ/SWJ/SJ are specifically designed with a top and a bottom. The top and bottom must be correctly positioned during installation to ensure structural integrity is maintained.

#### MultiStrut

Figure E2-03-02-01 Orientation



Figure E2-03-02-02



#### SteelWood

Figure E2-03-01-01 Orientation



Figure E2-03-01-02

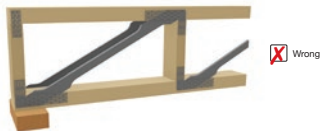

#### SpanJoist

Figure E2-03-03-01 Orientation

Common orientation



Figure E2-03-03-02

Other possible orientation



## 17.2 Bracing

For standard houses, brace at all supports with Type 1 braces at 1800mm centres, Type 2 at 2400mm or as specified. This applies to internal and external bearing points.

In all situations, bracing must be distributed as evenly as possible throughout the house.

### Type 1 bracing units - Timber diagonal brace

Figure E5-05-02-02

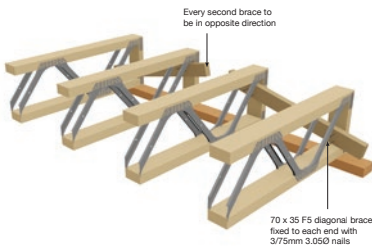
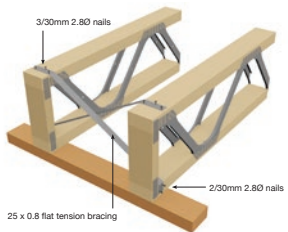

Figure E5-05-02-03



### Type 2 bracing units - Bracing panel construction

Figure E5-05-02-04

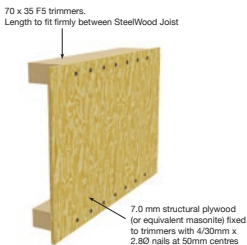
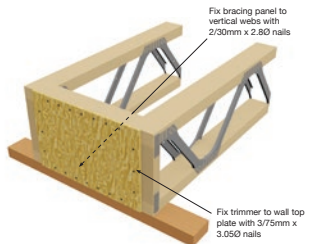

Figure E5-05-02-05



## 17.3 Strongbacks

Strongbacks are installed within the MSJ/SWJ/SJs at right angles to the direction of the joists and are used to dampen the vibrations by increasing the stiffness of the floor system and reduce deflection by load sharing.

Strongbacks must be fixed to the vertical webs in each MSJ/SWJ/SJ with 2/3.05 x 75mm nails.

Strongbacks can be located either to the underside of the top chord or sit on the bottom chord.

### Timber Splice to Strongback

Figure E5-02-02-01

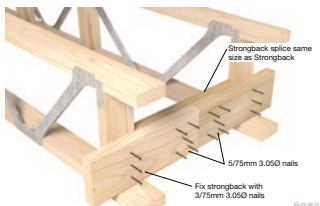

### Nailplate Splice to Strongback

Figure E5-02-02-02



### Positioning

Figure E5-02-02-06

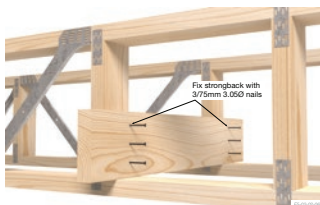

### Change of span

Figure E5-02-02-04

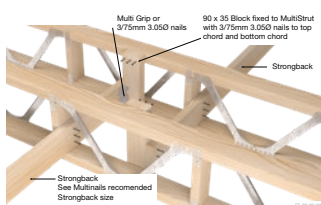



# Multinail - The Guide App available now!

The electronic version of **Multinail – The Guide** is a portable guide for construction using lightweight, pre-fabricated engineered timber products.

It provides the latest instructions for the correct installation and bracing of Multinail products, allowing builders and carpenters to check details on site with ease and reliability.

Search for '**Multinail**' in your app store.



## 18. Appendix - Document control

The Guide by:

**Multinail Australia PTY. LTD.**

**Head Office:** 155 Burnside Road, Stapylton, QLD 4207, AUSTRALIA

**Original Document Held:** Head Office

**Revision Number:** 17

**Last Updated:** 01/07/2023

© 2023 Multinail Australia Pty Ltd. ABN 79 003 999 586

*Whilst every effort is made to publish the facts, the authors and Multinail are not responsible for the accuracy or correctness of statements made or information contained in this publication or the consequences of any use made of the products, plans and information referred to in this publication.*

*This document is not to be reproduced wholly or in part without the express written permission of Multinail Australia Pty. Ltd.*



Personalised. Local. Progressive.

**Multinail Australia Pty. Ltd.**

ABN 79 003 999 586

155 Burnside Road  
Stapylton, QLD 4207

Phone: 07 3297 3250

Email: [enquiry@multinail.com](mailto:enquiry@multinail.com)

[www.multinail.com.au](http://www.multinail.com.au)

Your Multinail truss fabricator:

Multinail Australia Pty Ltd is proudly 100% Australian owned and operated.